



General-Purpose AC Servo

**MELSERVO**

MODEL

**Servo Motor**



INSTRUCTION MANUAL

## ● Safety Instructions ●

(Always read these instructions before using the equipment.)





Do not attempt to install, operate, maintain or inspect the servo amplifier and servo motor until you have read through this Instruction Manual, MELSERVO Servo Amplifier Installation Guide/Instruction Manual and appended documents carefully and can use the equipment correctly. Do not use the servo amplifier and servo motor until you have a full knowledge of the equipment, safety information and instructions.

In this Instruction Manual, the safety instruction levels are classified into "WARNING" and "CAUTION".

 <b>WARNING</b>	Indicates that incorrect handling may cause hazardous conditions, resulting in death or severe injury.
 <b>CAUTION</b>	Indicates that incorrect handling may cause hazardous conditions, resulting in medium or slight injury to personnel or may cause physical damage.

Note that the CAUTION level may lead to a serious consequence according to conditions. Please follow the instructions of both levels because they are important to personnel safety.

What must not be done and what must be done are indicated by the following diagrammatic symbols:

 : Indicates what must not be done. For example, "No Fire" is indicated by  .
 : Indicates what must be done. For example, grounding is indicated by  .

In this Instruction Manual, instructions at a lower level than the above, instructions for other functions, and so on are classified into "POINT".

After reading this installation guide, always keep it accessible to the operator.

1. To prevent electric shock, note the following:

 <b>WARNING</b>
<ul style="list-style-type: none"><li>• Before wiring or inspection, switch power off and wait for more than 10 minutes. Then, confirm the voltage is safe with voltage tester. Otherwise, you may get an electric shock.</li><li>• Connect the servo amplifier and servo motor to ground.</li><li>• Any person who is involved in wiring and inspection should be fully competent to do the work.</li><li>• Do not attempt to wire the servo amplifier and servo motor until they have been installed. Otherwise, you may get an electric shock.</li><li>• Operate the switches with dry hand to prevent an electric shock.</li><li>• The cables should not be damaged, stressed loaded, or pinched. Otherwise, you may get an electric shock.</li></ul>

2. To prevent fire, note the following:

 <b>CAUTION</b>
<ul style="list-style-type: none"><li>• Do not install the servo motor on or near combustibles. Otherwise a fire may cause.</li></ul>

3. To prevent injury, note the follow

 <b>CAUTION</b>
<ul style="list-style-type: none"><li>• Only the voltage specified in the Instruction Manual should be applied to each terminal, Otherwise, a burst, damage, etc. may occur.</li><li>• Connect the terminals correctly to prevent a burst, damage, etc.</li><li>• Ensure that polarity (+, -) is correct. Otherwise, a burst, damage, etc. may occur.</li><li>• During power-on or for some time after power-off, do not touch or close a parts (cable etc.) to the servo motor, etc. Their temperatures may be high and you may get burnt or a parts may damaged.</li></ul>

#### 4. Additional instructions

The following instructions should also be fully noted. Incorrect handling may cause a fault, injury, electric shock, etc.

##### (1) Transportation and installation

## ⚠ CAUTION

- Transport the products correctly according to their weights.
- Use the eye-bolt of the servo motor to only transport the servo motor and do not use it to transport in the condition to have installed a servo motor on the machine.
- Stacking in excess of the specified number of products is not allowed.
- Do not carry the motor by the cables, shaft or encoder.
- Install the servo amplifier in a load-bearing place in accordance with the Instruction Manual.
- Do not climb or stand on servo equipment. Do not put heavy objects on equipment.
- The servo motor must be installed in the specified direction.
- Do not install or operate the servo motor which has been damaged or has any parts missing.
- Do not block the intake/exhaust port of the servo motor which has a cooling fan.
- Provide adequate protection to prevent screws and other conductive matter, oil and other combustible matter from entering the servo motor.
- Do not drop or strike servo motor. Isolate from all impact loads.
- Use the servo motor under the following environmental conditions:

Environment		Conditions			
Ambient temperature	Operation	[°C]	0 to +40 (non-freezing)		
		[°F]	32 to 104 (non-freezing)		
	Storage	[°C]	-15 to 70 (non-freezing)		
		[°F]	5 to 158 (non-freezing)		
Ambient humidity	Operation	80%RH or less (non-condensing)			
	Storage	90%RH or less (non-condensing)			
Ambience		Indoors (no direct sunlight) Free from corrosive gas, flammable gas, oil mist, dust and dirt			
Altitude		Max. 1000m (3280 ft) above sea level			
(Note) Vibration	[m/s <sup>2</sup> ]	HC-KFS series H-MFS series	HC-UFS13 to 73	X,Y:49	
		HC-SFS81 HC-SFS52 to 152 HC-SFS53 to 153	HC-RFS series HC-UFS72 • 152	X,Y:24.5	
		HC-SFS121 • 201 HC-SFS202 • 352 HC-SFS203 • 353	HC-UFS202 to 502	X:24.5 Y:49	
		HC-SFS301 HC-SFS502 • 702		X:24.5 Y:29.4	
		HC-AQ series HC-KF series HC-MF series	HA-FF series HC-UF13 to 73	X,Y:19.6	
		HC-SF81 HC-SF52 to 152 HC-SF53 to 153	HC-RF series HC-UF72 • 152 HC-LFS52 to 152	X:9.8 Y:24.5	
		HC-SF121 • 201 HC-SF202 • 352 HC-SF203 • 353	HC-UF202 to 502 HC-LFS202 • 302	X:19.6 Y:49	
		HA-LFS502 • 702 HA-LFS601 to 12K1 HA-LFS701M to 15K1M HA-LH11K2 to 22K2	HA-LH11K2 to 22K2 HC-SF301 HC-SF502 • 702	X:11.7 Y:29.4	
		HA-LFS15K1 to 37K1 HA-LFS22K1M to 37K1M HA-LFS30K2 • 37K2	HA-LF series	X,Y:9.8	
		[ft/s <sup>2</sup> ]	HC-KFS series HC-MFS series	HC-UFS13 to 73	X,Y:161
			HC-SFS81 HC-SFS52 to 152 HC-SFS53 to 153	HC-RFS series HC-UFS72 • 152	X,Y:80
			HC-SFS121 • 201 HC-SFS202 • 352 HC-SFS203 • 353	HC-UFS202 to 502	X:80 Y:161

## CAUTION

Environment		Conditions	
(Note) Vibration	[ft/s <sup>2</sup> ]	HC-SFS301 HC-SFS502 · 702	X:80 Y:96
		HC-AQ series HC-KF series HC-MF series	HA-FF series HC-UF13 to 73 X,Y:64
		HC-SF81 HC-SF52 to 152 HC-SF53 to 153	HC-RF series HC-UFS72 · 152 HC-LFS52 to 152 X:32 Y:80
		HC-SF121 · 201 HC-SF202 · 352 HC-SF203 · 353	HC-UF202 to 502 HC-LFS202 · 302 X:64 Y:161
		HA-LFS502 · 702 HA-LFS601 to 12K1 HA-LFS701M to 15K1M HA-LH11K2 to 22K2	HA-LH11K2 to 22K2 HC-SF301 HC-SF502 · 702 X:38.4 Y:96.5
		HA-LFS15K1 to 37K1 HA-LFS22K1M to 37K1M HA-LFS30K2 · 37K2	HA-LF series X,Y:32

Note: Except the servo motor with reduction gear.

- Securely attach the servo motor to the machine. If attach insecurely, the servo motor may come off during operation.
- The servo motor with reduction gear must be installed in the specified direction to prevent oil leakage.
- For safety of personnel, always cover rotating and moving parts.
- Never hit the servo motor or shaft, especially when coupling the servo motor to the machine. The encoder may become faulty.
- Do not subject the servo motor shaft to more than the permissible load. Otherwise, the shaft may break.
- When the equipment has been stored for an extended period of time, consult Mitsubishi.

### (2) Wiring

## CAUTION

- Wire the equipment correctly and securely. Otherwise, the servo motor may misoperate.
- Do not install a power capacitor, surge absorber or radio noise filter (FR-BIF option) between the servo motor and servo amplifier.
- Connect the output terminals (U, V, W) correctly. Otherwise, the servo motor will operate improperly.
- Do not connect AC power directly to the servo motor. Otherwise, a fault may occur.

### (3) Test run adjustment

## CAUTION

- Before operation, check the parameter settings. Improper settings may cause some machines to perform unexpected operation.
- The parameter settings must not be changed excessively. Operation will be instable.

#### (4) Usage

### ⚠ CAUTION

- Provide an external emergency stop circuit to ensure that operation can be stopped and power switched off immediately.
- Any person who is involved in disassembly and repair should be fully competent to do the work.
- Do not modify the equipment.
- Use the servo amplifier with the specified servo motor.
- The electromagnetic brake on the servo motor is designed to hold the motor shaft and should not be used for ordinary braking.
- For such reasons as service life and mechanical structure (e.g. where a ballscrew and the servo motor are coupled via a timing belt), the electromagnetic brake may not hold the motor shaft. To ensure safety, install a stopper on the machine side.

#### (5) Corrective actions

### ⚠ CAUTION

- When it is assumed that a hazardous condition may take place at the occur due to a power failure or a product fault, use a servo motor with electromagnetic brake or an external brake mechanism for the purpose of prevention.
- Configure the electromagnetic brake circuit so that it is activated not only by the servo amplifier signals but also by an external emergency (forced) stop signal.

Contacts must be open when servo-on signal is off, when an alarm (trouble) is present and when an electromagnetic brake signal.

Circuit must be opened during emergency (force) stop.

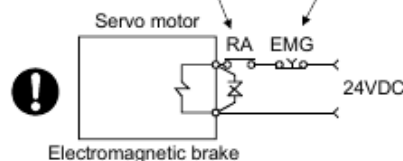

- When any alarm has occurred, eliminate its cause, ensure safety, and deactivate the alarm before restarting operation.
- When power is restored after an instantaneous power failure, keep away from the machine because the machine may be restarted suddenly (design the machine so that it is secured against hazard if restarted).

## ● About processing of waste ●

When you discard servo amplifier, a battery (primary battery), and other option articles, please follow the law of each country (area).

### ⚠ FOR MAXIMUM SAFETY

- This product is not designed or manufactured to be used in equipment or systems in situations that can affect or endanger human life.
- When considering this product for operation in special applications such as machinery or systems used in passenger transportation, medical, aerospace, atomic power, electric power, or submarine repeating applications, please contact your nearest Mitsubishi sales representative.
- Although this product was manufactured under conditions of strict quality control, you are strongly advised to install safety devices to forestall serious accidents when it is used in facilities where a breakdown in the product is likely to cause a serious accident.

# COMPLIANCE WITH EC DIRECTIVES

## 1. WHAT ARE EC DIRECTIVES?

The EC Directives were issued to standardize the regulations of the EU countries and ensure smooth distribution of safety-guaranteed products. In the EU countries, the Machinery Directive (effective in January, 1995), EMC Directive (effective in January, 1996) and Low Voltage Directive (effective in January, 1997) of the EC Directives require that products to be sold should meet their fundamental safety requirements and carry the CE marks (CE marking). CE marking applies to machines and equipment into which servo amplifiers have been installed.

The servo amplifiers do not function independently but are designed for use with machines and equipment.

Therefore, the CE marking does not apply to the servo amplifiers but applies to the machines and equipment into which the servo amplifiers are installed.

This servo amplifier conforms to the standards related to the Low Voltage Directive to facilitate CE marking on machines and equipment into which the servo amplifiers will be installed. To ensure ease of compliance with the EMC Directive, Mitsubishi Electric prepared the "EMC INSTALLATION GUIDELINES" (IB(NA)67310) which provides servo amplifier installation, control box making and other procedures. Please contact your sales representative.

## 2. PRECAUTIONS FOR COMPLIANCE

Use the servo motor compatible with the EN Standard.

Unless otherwise specified, the handling, performance, specifications and others of the EN Standard-compatible models are the same as those of the standard models.

To comply with the EN Standard, also observe the following items strictly.

### (1) Wiring

- (a) Use a fixed terminal block to connect the power supply lead of the servo motor to the servo amplifier. Do not connect cables directly.



Terminal block



- (b) Use the servo motor side power connector which complies with the EN Standard. The EN Standard-compliant power connector sets are available from us as options.

Power Connector Set Model	Servo Motor Model
MR-PWCF	HC-FF□C(B)-UE
MR-PWCNS1	HC-SF81(B) HC-SF52(B) to 152(B) HC-SF53(B) to 153(B) HC-RF103(B) to 203(B) HC-UF72(B) · 152(B) HC-SF581(B) HC-SFS52(B) to 152(B) HC-SFS53(B) to 153(B) HC-RFS103(B) to 203(B) HC-UFS72(B) · 152(B) HC-LFS52(B) to 152(B)
MR-PWCNS2	HC-SF121(B) to 301(B) HC-SF202(B) to 502(B) HC-SF203(B) · 353(B) HC-RF353(B) · 503(B) HC-UF202(B) to 502(B) HC-SF5121(B) to 301(B) HC-SFS202(B) to 502(B) HC-SFS203(B) · 353(B) HC-RFS353(B) · 503(B) HC-UFS202(B) to 502(B) HA-LFS502 HC-LFS202(B) · 302(B)
MR-PWCNS3	HC-SFS702(B) · HC-SF702(B) HA-LFS702

### (2) Installation

The flange of the machine mounted with the HC-MF (HC-MF-UE)/HC-KF (HC-KF-UE)/HC-AQ/HC-MFS/HC-KFS must be connected to the earth.

## CONFORMANCE WITH UL/C-UL STANDARD

Use the UL/C-UL Standard-compliant model of servo motor.

Unless otherwise specified, the handling, performance, specifications, etc. of the UL/C-UL Standard-compliant models are the same as those of the standard models.

Strictly observe the following items to conform to the UL/C-UL Standard.

The flange sizes in this table assume that the flanges are made of aluminum.

The rated torque of the servo motor indicates the continuous permissible torque value that can be generated when it is mounted on the flange specified in the following table and used in the environment of 40°C ambient temperature.

Flange Size [mm]	Servo Motor								
	HC-KF(-UE) HC-KFS	HC-MF(-UE) HC-MFS	HA-FF□C -UE	HC-SF HC-SFS	HC-RF HC-RFS	HC-UF HC-UFS	HA-LF HA-LFS	HC-LFS	HC-AQ
150 × 150 × 3									0135 to 0335
150 × 150 × 6	053 · 13	053 · 13	053 · 13			13			
250 × 250 × 6	23	23	23 · 33			23			
250 × 250 × 12	43	43	43 · 63	81 52 to 152 53 to 153	103 to 203	43		52 to 152	
300 × 300 × 12	(Note)73	73				73			
300 × 300 × 20				121 · 201 202 · 352 203 · 353				202 · 302	
550 × 550 × 30					353 · 503	72 · 152			
650 × 650 × 35				301 502 · 702		202 to 502	601 to 12K 1 701M to 15K 1M 502 to 22K 2		
950 × 950 × 35							15K 1 to 37K 1 22K 1M to 37K 1M 30K 2 · 37K 2		

Note: 73 is not available for the HC-KF(-UE) series.





# CONTENTS

<b>1. INTRODUCTION</b>	<b>1 - 1 to 1 -12</b>
1.1 Servo motor features.....	1 - 1
1.2 Model name make-up.....	1 - 1
1.3 Parts identification.....	1 -11
<b>2. INSTALLATION</b>	<b>2 - 1 to 2 -12</b>
2.1 Environmental conditions.....	2 - 2
2.2 Installation orientation.....	2 - 3
2.3 Load remove precautions.....	2 - 3
2.4 Permissible load for the shaft.....	2 - 4
2.4.1 Without reduction gear .....	2 - 4
2.4.2 With reduction gear.....	2 - 6
2.5 Protection from oil and water.....	2 -10
2.6 Cooling fan.....	2 -12
2.7 Cable.....	2 -12
<b>3. CONNECTORS USED FOR SERVO MOTOR WIRING</b>	<b>3 - 1 to 3 -20</b>
3.1 Makeups.....	3 - 1
3.1.1 HC-KF(-UE) · HC-MF(-UE) · HA-FF · HC-UF 3000r/min series .....	3 - 1
3.1.2 HA-FF□C-UE series.....	3 - 1
3.1.3 HC-SF(S) · HC-RF(S) · HC-UF(S)2000r/min, HA-LH · HA-LF · HA-LFS · HC-LFS series.....	3 - 7
3.1.4 HC-AQ series.....	3 -15
3.1.5 HC-KFS · HC-MFS · HC-UFS3000r/min series .....	3 -15
3.1.6 HC-UF 3000r/min series (Compliance with IP65) .....	3 -16
3.2 IP65, EN Standard-compliant options .....	3 -17
3.3 Signal arrangement of encoder connectors.....	3 -19
<b>4. INSPECTION</b>	<b>4 - 1 to 4 - 2</b>
<b>5. SPECIFICATIONS</b>	<b>5 - 1 to 5 -36</b>
5.1 Standard specifications.....	5 - 1
5.2 Torque characteristics.....	5 -18
5.3 Servo motors with reduction gears .....	5 -30
5.4 Servo motors with special shafts.....	5 -34
5.4.1 Keyway.....	5 -34
5.4.2 D cut.....	5 -35
5.4.3 Straight (HC-AQ).....	5 -35
<b>6. CHARACTERISTICS</b>	<b>6 - 1 to 6 - 6</b>
6.1 Electromagnetic brake characteristics .....	6 - 1
6.2 Vibration rank.....	6 - 4
6.3 Machine Accuracies.....	6 - 5

<b>7. OUTLINE DIMENSION DRAWINGS</b>	<b>7 - 1 to 7 -312</b>
--------------------------------------	------------------------

7.1 Servo motors.....	7 - 1
7.1.1 HC-MF · HC-KF series.....	7 - 1
7.1.2 HA-FF series.....	7 -23
7.1.3 HC-SF · HC-SFS series.....	7 -50
7.1.4 HC-RF · HC-RFS series.....	7 -90
7.1.5 HC-UF 2000r/min·HC-UFS 2000r/min series.....	7 -97
7.1.6 HC-UF 3000r/min series.....	7 -100
7.1.7 HC-UF 3000r/min, HC-UFS3000r/min series with IP65-compliant connectors.....	7 -103
7.1.8 HA-LH series.....	7 -106
7.1.9 HC-AQ series.....	7 -108
7.1.10 HA-LF series.....	7 -109
7.1.11 HC-MFS · HC-KFS series.....	7 -113
7.1.12 HC-UFS 3000r/min series.....	7 -132
7.1.13 HA-LFS series.....	7 -135
7.1.14 HC-LFS series.....	7 -147
7.2 Servo motors (in inches).....	7 -152
7.2.1 HC-MF · HC-KF series.....	7 -152
7.2.2 HA-FF series.....	7 -174
7.2.3 HC-SF · HC-SFS series.....	7 -201
7.2.4 HC-RF · HC-RFS series.....	7 -241
7.2.5 HC-UF 2000r/min · HC-UFS 2000r/min series.....	7 -248
7.2.6 HC-UF 3000r/min series.....	7 -251
7.2.7 HC-UF 3000r/min, HC-UFS3000r/min series with IP65-compliant connectors.....	7 -254
7.2.8 HA-LH series.....	7 -257
7.2.9 HC-AQ series.....	7 -259
7.2.10 HA-LF series.....	7 -260
7.2.11 HC-MFS · HC-KFS series.....	7 -264
7.2.12 HC-UFS 3000r/min series.....	7 -283
7.2.13 HA-LFS series.....	7 -286
7.2.14 HC-LFS series.....	7 -298
7.3 Connector.....	7 -303

<b>8. CALCULATION METHODS FOR DESIGNING</b>	<b>8 - 1 to 8 -14</b>
---	-----------------------

8.1 Specification symbol list.....	8 - 1
8.2 Position resolution and electronic gear setting.....	8 - 2
8.3 Speed and command pulse frequency.....	8 - 3
8.4 Stopping characteristics.....	8 - 4
8.5 Capacity selection.....	8 - 5
8.6 Load torque equations.....	8 - 8
8.7 Expression for Calculating the Electromagnetic Brake Workload.....	8 - 8
8.8 Load inertia moment equations.....	8 - 9
8.9 Precautions for zeroing.....	8 -10
8.10 Selection example.....	8 -11

Appendix.1 Servo motor ID codes ..... App - 1



# 1. INTRODUCTION

## 1. INTRODUCTION

### 1.1 Servo motor features

Servo Motor Series	Features (Points Different from Conventional Products)	Positioning Resolution [pulses/rev]	Rated Speed [r/min]	Capacity [kW]	Interchangeable Servo Motor Series	Compliance with Overseas Standards	Environmental Resistance
HC-KF	Low inertia, small capacity 4 to 5 times greater in inertia moment than HC-MF(S). Equipped with absolute position detector as standard	8192	3000	0.05 to 0.4	HC-MF HC-ME HC-MH	EN Standard UL/C-UL Standard (Standard model is compliant)	(Note1・2) IP44
HC-KFS		131072				EN Standard UL/C-UL Standard (Standard model is compliant)	(Note1・2) IP55
HC-MF	Ultra low inertia, small capacity 1.2 times higher in power rate than HA-ME Equipped with absolute position detector as standard	8192	3000	0.05 to 0.75	HA-ME HA-MH	EN Standard UL/C-UL Standard (Standard model is compliant)	(Note1・2) IP44
HC-MFS		131072				EN Standard UL/C-UL Standard (Standard model is compliant)	(Note1・2) IP55
HA-FF	Low inertia, small capacity Equipped with absolute position detector as standard	3000	8192	0.05 to 0.6	HA-FE HA-FH	EN Standard UL/C-UL Standard (HA-FF-UE is compliant)	(Note1・2) IP44
HC-SF	Middle inertia, middle capacity 1.5 times higher in power rate than HA-SE Equipped with absolute position detector as standard	16384	1000 2000 3000	0.5 to 7	HA-SE HA-SH	EN Standard UL/C-UL Standard (Standard model is compliant)	IP65
HC-SFS		131072					
HC-RF	Ultra low inertia, middle capacity About 3 times higher in power rate than HA-LH Equipped with absolute position detector as standard	16384	3000	1 to 5		EN Standard UL/C-UL Standard (Standard model is compliant)	IP65
HC-RFS		131072					
HC-UF	Pancake type, small capacity Equipped with absolute position detector as standard	8192	3000	0.1 to 0.75		EN Standard UL/C-UL Standard (Standard model is compliant)	(Note1) IP65
	Pancake type, middle capacity Equipped with absolute position detector as standard	16384	2000	0.75 to 5			IP65
HC-UFS	Pancake type small capacity Equipped with absolute position detector as standard	131072	3000	0.1 to 0.75		EN Standard UL/C-UL Standard (Standard model is compliant)	(Note1) IP65
	Pancake type middle capacity Equipped with absolute position detector as standard		2000	0.75 to 5			IP65
HA-LH	Low inertia, large capacity	16384	2000	11 to 22		EN Standard (HA-LH-EC is compliant)	JP44
HC-AQ	24VDC-compatible, ultra low inertia, small capacity	8192	3000	0.01 to 0.03		EN Standard, UL/C-UL Standard (Standard model is compliant)	(Note1・2) IP55
HA-LF	Three-phase, 200VAC-compatible, low inertia, large capacity Equipped with absolute position detector as standard	16384	2000	30・37		Scheduled to make application	IP44
	Three-phase, 400VAC-compatible, low inertia, large capacity Equipped with absolute position detector as standard			30 to 55			
HA-LFS	Low inertia, large capacity Equipped with absolute position detector as standard	1000	131072	6 to 20	HA-LH	Being planned	IP44
		1500		7 to 30			
		2000		5 to 37			
HC-LFS	Low inertia, middle capacity Equipped with absolute position detector as standard	2000	131072	0.5 to 3.0	HA-LH	Scheduled to make application	IP65

Note 1: Except connector section.

2: Except for the shaft-through portion.

### 1.2 Model name make-up

#### (1) Name plate

 <b>MITSUBISHI</b>	
AC SERVO MOTOR	
<b>HC-RF153</b>	
INPUT 3AC 145V 8.2A	
OUTPUT 1.5Kw IEC34-1 1994	
SPEED 3000r/min	
SER.No. 001 DATE	
MITSUBISHI ELECTRIC CORPORATION MADE IN JAPAN	

Model

Input power

Rated output

Rated speed

Serial number

# 1. INTRODUCTION

## (2) Model

### (a) HC-MF series (ultra low inertia, small capacity)

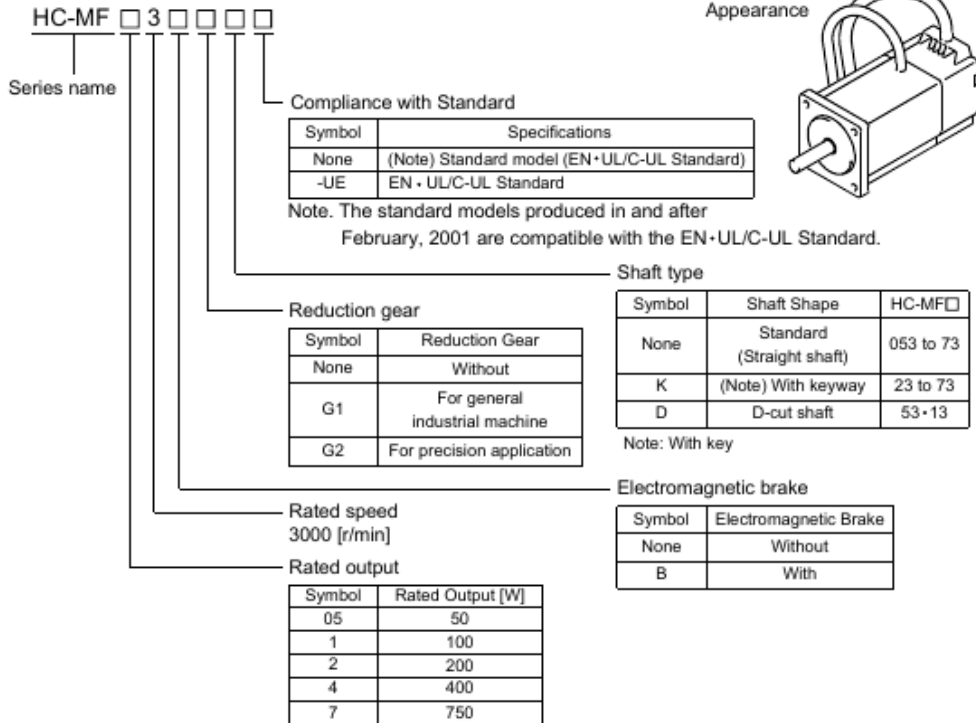

### (b) HA-FF series (low inertia, small capacity)

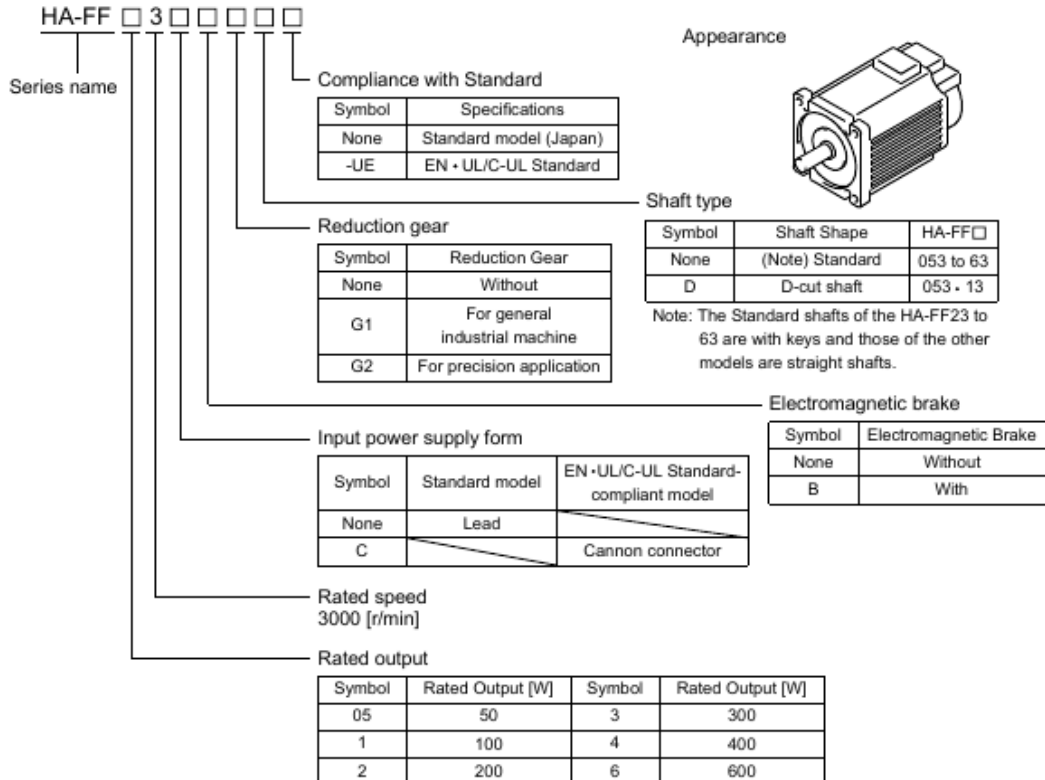

# 1. INTRODUCTION

## (c) HC-SF series (middle inertia, middle capacity)

HC-SF □ □ □ □ □  
Series name

### Shaft type

Symbol	Shaft Shape
None	Standard (Straight shaft)
K	With keyway

Note: Without key

### Reduction gear

Symbol	(Note) Reduction Gear
None	Without
G1	For general industrial machine (flange type)
G1H	For general industrial machine (leg type)
G2	For precision application

Note: Not provided for 1000r/min and 3000r/min series.

### Rated speed

Symbol	Speed [r/min]
1	1000
2	2000
3	3000

### Electromagnetic brake

Symbol	Electromagnetic Brake
None	Without
B	With

### Rated output

Symbol	Rated Output [W]	1000 [r/min]	2000 [r/min]	3000 [r/min]
5	500	○	○	○
8	850	○	○	○
10	1000	○	○	○
12	1200	○	○	○
15	1500	○	○	○
20	2000	○	○	○
30	3000	○	○	○
35	3500	○	○	○
50	5000	○	○	○
70	7000	○	○	○

Appearance

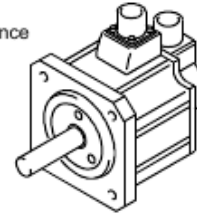



# 1. INTRODUCTION

## (d) HC-RF series (ultra low inertia, middle capacity)

HC-RF □ 3 □ □ □

Series name

Shaft type

Symbol	Shaft Shape
None	Standard (Straight shaft)
K	With keyway

Note: Without key

Reduction gear

Symbol	Reduction Gear
None	Without
G2	For precision application

Rated speed 3000 [r/min]

Rated output

Symbol	Rated Output [W]
10	1000
15	1500
20	2000
35	3500
50	5000

Electromagnetic brake

Symbol	Electromagnetic Brake
None	Without
B	With

Appearance

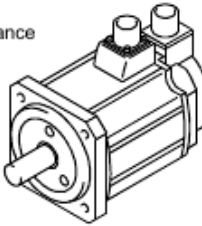

## (e) HC-UF series (pancake type, small and middle capacity)

HC-UF □ □ □ □

Series name

Shaft type

Symbol	Shaft Shape	HC-UF □
None	Standard (Straight shaft)	13 to 43 72 to 202
K	(Note) With keyway	
D	D-cut shaft	13

Note: HC-UF 23 to 73 are provided with keys.

Rated speed

Symbol	Speed [r/min]
2	2000
3	3000

Rated output

Symbol	Rated Output [W]
1	100
2	200
4	400
7	750
15	1500
20	2000
35	3500
50	5000

Electromagnetic brake

Symbol	Electromagnetic Brake
None	Without
B	With

Appearance

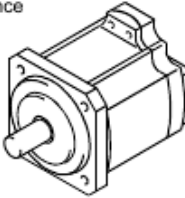

# 1. INTRODUCTION

## (f) HA-LH series (low inertia, large capacity)

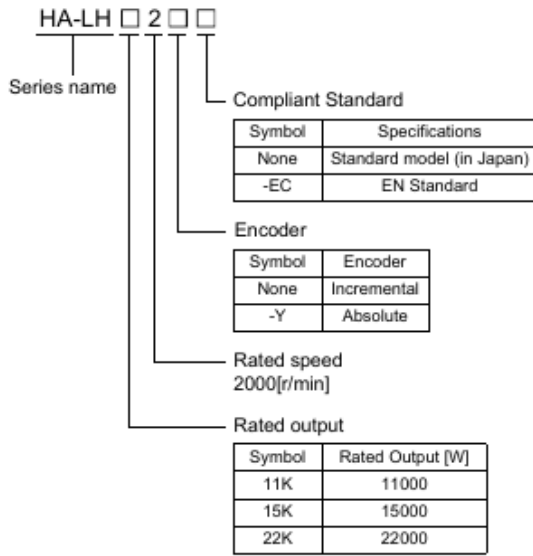

Appearance

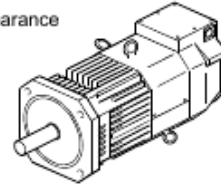

## (g) HC-KF series (low inertia, small capacity)

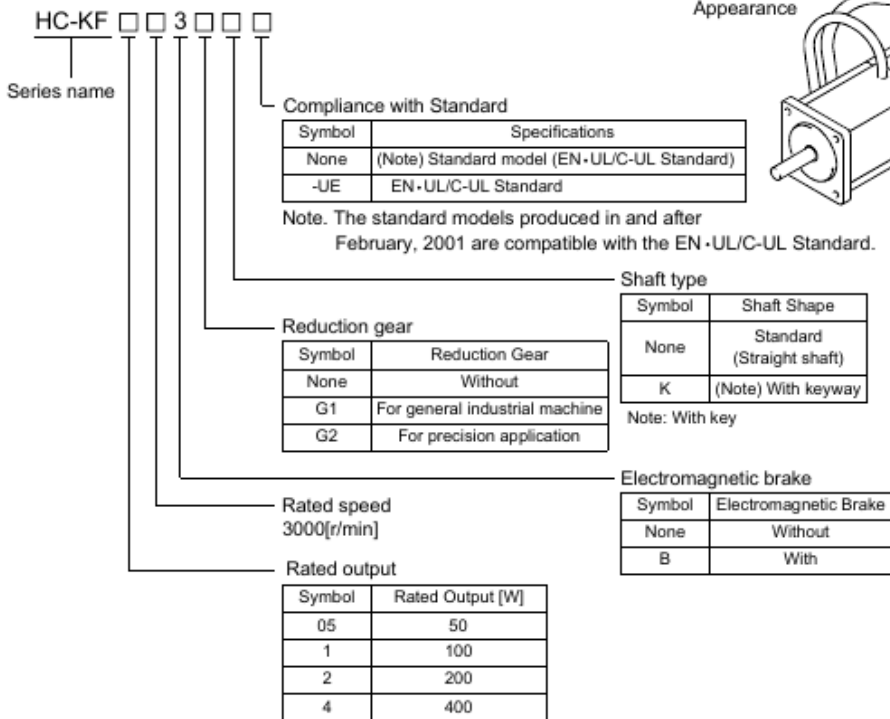

Appearance

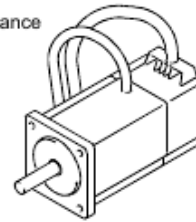

# 1. INTRODUCTION

(h) HC-AQ series (24VDC-compatible, ultra low inertia, small capacity)

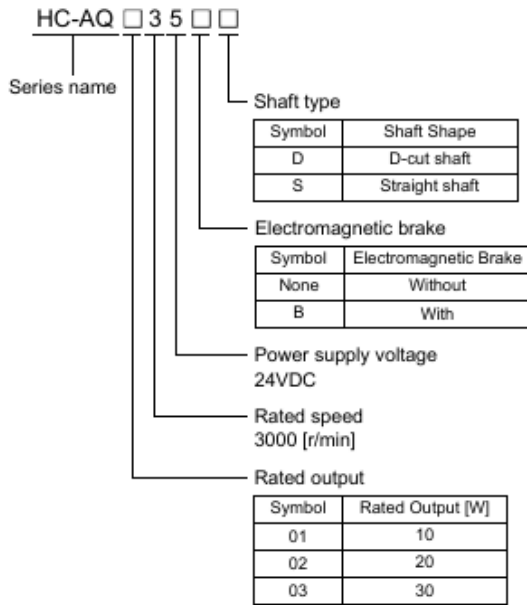

Appearance

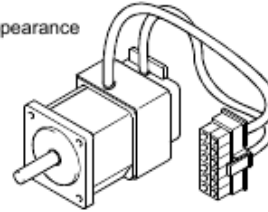

(i) HA-LF series (Three-phase, 200 · 400VAC-compatible, low inertia, large capacity)

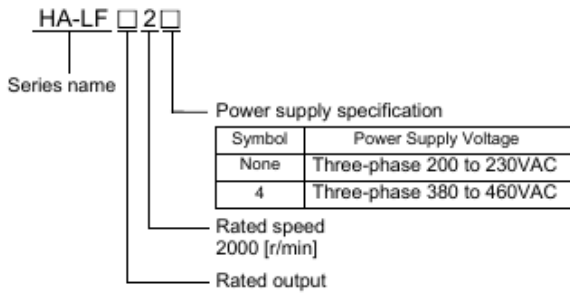

Appearance

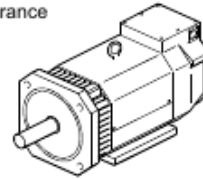

Symbol	Rated Output [kW]	Power supply specifications	
		Three-phase 200 to 230VAC	Three-phase 380 to 460VAC
30K	30	○	○
37K	37	○	○
45K	45	○	○
55K	55	○	○

# 1. INTRODUCTION

## (j) HC-KFS series (low inertia, small capacity, high resolution)

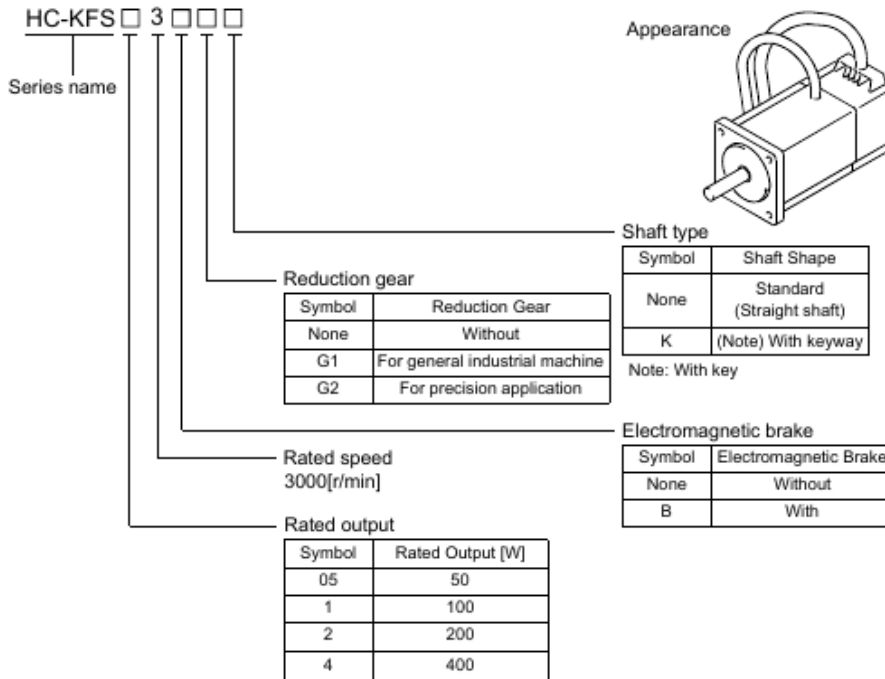

## (k) HC-MFS series (ultra low inertia, small capacity, high resolution)

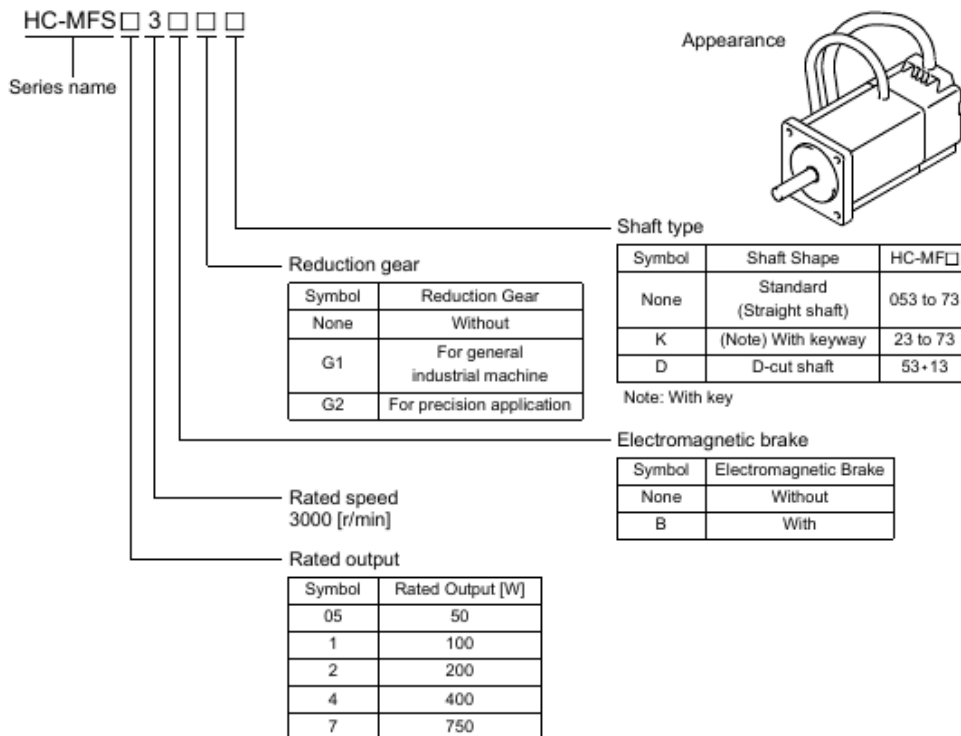

# 1. INTRODUCTION

(I) HC-SFS series (middle inertia, middle capacity, high resolution)

HC-SFS □ □ □ □

Series name

Shaft type

Symbol	Shaft Shape
None	Standard (Straight shaft)
K	With keyway

Note: Without key

Reduction gear

Symbol	(Note) Reduction Gear
None	Without
G1	For general industrial machine (flange type)
G1H	For general industrial machine (leg type)
G2	For precision application

Note: Not provided for 1000r/min and 3000r/min series.

Rated speed

Symbol	Speed [r/min]
1	1000
2	2000
3	3000

Electromagnetic brake

Symbol	Electromagnetic Brake
None	Without
B	With

Rated output

Symbol	Rated Output [W]	1000 [r/min]	2000 [r/min]	3000 [r/min]
5	500	○	○	○
8	850	○	○	○
10	1000	○	○	○
12	1200	○	○	○
15	1500	○	○	○
20	2000	○	○	○
30	3000	○	○	○
35	3500	○	○	○
50	5000	○	○	○
70	7000	○	○	○

Appearance

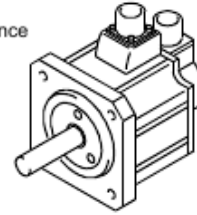

# 1. INTRODUCTION

(m) HC-RFS series (ultra low inertia, middle capacity, high resolution)

HC-RFS □ 3 □ □ □

Series name

Shaft type

Symbol	Shaft Shape
None	Standard (Straight shaft)
K	(Note) With keyway

Note: Without key

Reduction gear

Symbol	Reduction Gear
None	Without
G2	For precision application

Rated speed 3000 [r/min]

Rated output

Symbol	Rated Output [W]
10	1000
15	1500
20	2000
35	3500
50	5000

Electromagnetic brake

Symbol	Electromagnetic Brake
None	Without
B	With

Appearance

(n) HC-UFS series (pancake type small and middle capacity, high resolution)

HC-UFS □ □ □ □

Series name

Shaft type

Symbol	Shaft Shape	HC-UFS □
None	Standard (Straight shaft)	13 to 43 72 to 202
K	(Note) With keyway	
D	D-cut shaft	13

Note: HC-UFS 23 to 73 are provided with keys.

Rated speed

Symbol	Speed [r/min]
2	2000
3	3000

Rated output

Symbol	Rated Output [W]
1	100
2	200
4	400
7	750
15	1500
20	2000
35	3500
50	5000

Electromagnetic brake

Symbol	Electromagnetic Brake
None	Without
B	With

Appearance

# 1. INTRODUCTION

(o) HA-LFS series (low inertia, large capacity, high resolution)

HA-LFS □ □

Series name

Rated speed

Symbol	Speed [r/min]
1	1000
1M	1500
2	2000

Rated output

Symbol	Rated Output [kW]	1000 [r/min]	1500 [r/min]	2000 [r/min]
50	5	○	○	○
60	6	○	○	○
70	7	○	○	○
80	8	○	○	○
11K	11	○	○	○
12K	12	○	○	○
15K	15	○	○	○
20K	20	○	○	○
22K	22	○	○	○
25K	25	○	○	○
30K	30	○	○	○
37K	37	○	○	○

Appearance

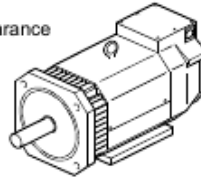

(p) HC-LFS series (low inertia, middle capacity, high resolution)

HC-LFS □ 2 □

Series name

Electromagnetic brake

Symbol	Electromagnetic Brake
None	Without
B	With

Rated speed  
2000 [r/min]

Rated output

Symbol	Rated Output [kW]
5	0.5
10	1
15	1.5
20	2
30	3

Appearance

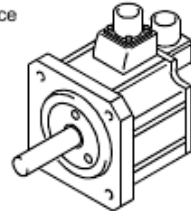

# 1. INTRODUCTION

## 1.3 Parts identification

Lead type

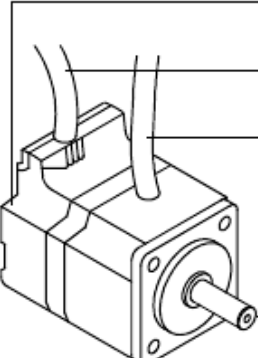

Name/Application	Reference
Encoder	Section 5.1
Encoder cable with encoder connector	Section 3.2
Power cable <ul style="list-style-type: none"> <li>• Power lead (U·V·W)</li> <li>• Earth lead</li> <li>• Brake lead (for motor with electromagnetic brake)</li> </ul>	Chapter 7
Servo motor shaft	Chapter 2 Section 5.4

Connector type

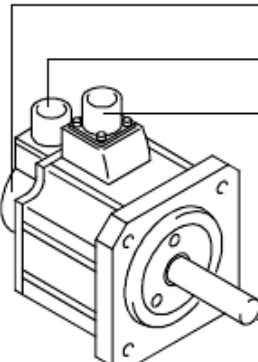

Name/Application	Reference
Encoder	Section 5.1
Encoder connector	Section 3.2
Power connector <ul style="list-style-type: none"> <li>• Power supply (U·V·W)</li> <li>• Earth</li> <li>• Brake (for motor with electromagnetic brake) Some motors with electromagnetic brakes have brake connectors separately.</li> </ul>	Chapter 7
Servo motor shaft	Chapter 2 Section 5.4

Terminal box type

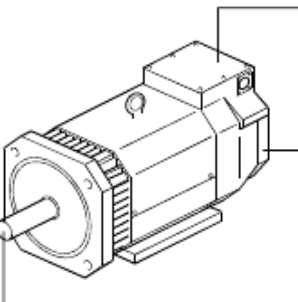

Name/Application	Reference
Terminal box <ul style="list-style-type: none"> <li>• Power leads (U·V·W)</li> <li>• Cooling fan leads</li> <li>• Ground terminal</li> <li>• Brake lead (for motor with electromagnetic brake)</li> <li>• Encoder connector</li> </ul>	Chapter 7 Section 3.2
Encoder	Section 5.1
Servo motor shaft	Chapter 2





## 2. INSTALLATION

---

### 2. INSTALLATION



- Stacking in excess of the limited number of products is not allowed.
- Install the equipment to incombustibles. Installing them directly or close to combustibles will lead to a fire.
- Install the equipment in a load-bearing place in accordance with this Instruction Manual.
- Do not get on or put heavy load on the equipment to prevent injury.
- Use the equipment within the specified environmental condition range.
- Do not subject the servo motor to drop impact or shock loads as they are precision equipment.
- Do not install or operate a faulty servo amplifier.
- Do not hold the cable, shaft or encoder to carry the servo motor. Otherwise, a fault or injury may occur.
- The lifting eyebolts of the servo motor may only be used to transport the servo motor. They must not be used to transport the servo motor when it is mounted on a machine.
- The servo motor with reduction gear must be installed in the specified direction. Otherwise, it can leak oil, leading to a fire or fault.
- Securely fix the servo motor to the machine. If fixed insecurely, the servo motor will come off during operation, leading to injury.
- When coupling the shaft end of the servo motor, do not subject the shaft end to impact, such as hammering. The encoder may become faulty.
- When coupling a load to the servo motor, do not use a rigid coupling. Doing so can cause the shaft to break.
- Cover the shaft of the servo motor to make its rotary part completely inaccessible during operation.
- Do not subject the servo motor shaft to more than the permissible load. Otherwise, the shaft may break, leading to injury.
- When the product has been stored for an extended period of time, consult Mitsubishi.

## 2. INSTALLATION

### 2.1 Environmental conditions

Environment		Conditions		
Ambient temperature	Operation	[°C]	0 to +40 (non-freezing)	
		[°F]	32 to 104 (non-freezing)	
Storage		[°C]	-15 to 70 (non-freezing)	
		[°F]	5 to 158 (non-freezing)	
Ambient humidity	Operation		80%RH or less (non-condensing)	
	Storage		90%RH or less (non-condensing)	
Ambience		Indoors (no direct sunlight) Free from corrosive gas, flammable gas, oil mist, dust and dirt		
Altitude		Max. 1000m (3280 ft) above sea level		
(Note) Vibration	[m/s <sup>2</sup> ]	HC-KFS series H-MFS series	HC-UF513 to 73	X,Y:49
		HC-SF581 HC-SF552 to 152 HC-SF553 to 153	HC-RFS series HC-UF572 · 152	X,Y:24.5
		HC-SF5121 · 201 HC-SF5202 · 352 HC-SF5203 · 353	HC-UF5202 to 502	X:24.5 Y:49
		HC-SF5301 HC-SF5502 · 702		X:24.5 Y:29.4
		HC-AQ series HC-KF series HC-MF series	HA-FF series HC-UF13 to 73	X,Y:19.6
		HC-SF81 HC-SF52 to 152 HC-SF53 to 153	HC-RF series HC-UF72 · 152 HC-LF552 to152	X:9.8 Y:24.5
		HC-SF121 · 201 HC-SF202 · 352 HC-SF203 · 353	HC-UF202 to 502 HC-LF5202 · 302	X:19.6 Y:49
		HA-LF5502 · 702 HA-LF5601 to12K1 HA-LF5701M to 15K1M HA-LH11K2 to 22K2	HA-LH11K2 to 22K2 HC-SF301 HC-SF502 · 702	X:11.7 Y:29.4
		HA-LF515K1 to 37K1 HA-LF522K1M to 37K1M HA-LF530K2 · 37K2	HA-LF series	X,Y:9.8
		[ft/s <sup>2</sup> ]	HC-KFS series HC-MFS series	HC-UF513 to 73
	HC-SF581 HC-SF552 to 152 HC-SF553 to 153		HC-RFS series HC-UF572 · 152	X,Y:80
	HC-SF5121 · 201 HC-SF5202 · 352 HC-SF5203 · 353		HC-UF5202 to 502	X:80 Y:161
	HC-SF5301 HC-SF5502 · 702			X:80 Y:96
	HC-AQ series HC-KF series HC-MF series		HA-FF series HC-UF13 to 73	X,Y:64
	HC-SF81 HC-SF52 to 152 HC-SF53 to 153		HC-RF series HC-UF72 · 152 HC-LF552 to152	X:32 Y:80
	HC-SF121 · 201 HC-SF202 · 352 HC-SF203 · 353		HC-UF202 to 502 HC-LF5202 · 302	X:64 Y:161
	HA-LF5502 · 702 HA-LF5601 to12K1 HA-LF5701M to 15K1M HA-LH11K2 to 22K2		HA-LH11K2 to 22K2 HC-SF301 HC-SF502 · 702	X:38.4 Y:96.5
	HA-LF515K1 to 37K1 HA-LF522K1M to 37K1M HA-LF530K2 · 37K2		HA-LF series	X,Y:32

Note: Except the servo motor with reduction gear.

Vibration occurs in the directions shown below. The values were measured at the portion which indicates the maximum value (normally the bracket opposite to load side). When the servo motor is at a stop, the bearings are likely to fret and vibration should therefore be suppressed to about half of the permissible value.

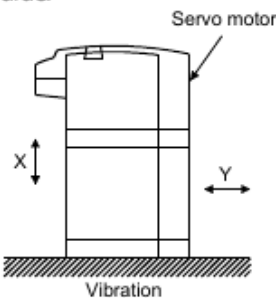

Graph of vibration servo amplitude vs. speed

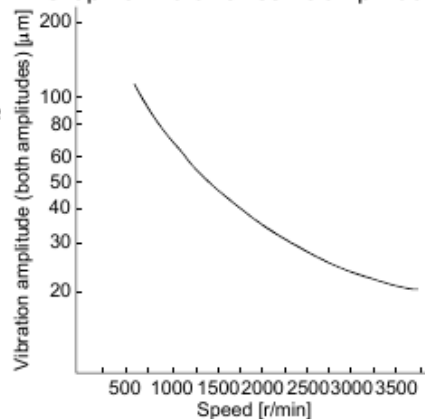

## 2. INSTALLATION

### 2.2 Installation orientation

The following table lists directions of installation:

Servo Motor Series	Direction of Installation	Remarks
HC-KF HC-MF HA-FF HC-SF HC-RF HC-UF HC-KFS HC-MFS HC-SFS HC-RFS HC-UFS HC-LFS	May be installed in any direction.	For installation in the horizontal direction, it is recommended to set the connector section downward.
HC-AQ HA-LH HA-LFS (Flange type)		
HA-LF HA-LFS (Flange · leg type)	Horizontal direction with the legs downward.	Use either the legs or flange for installation.

When the servo motor with electromagnetic brake is installed with the shaft end at top, the brake plate may generate sliding sound but it is not a fault. Refer to Section 5.3 for the installation orientation of the servo motor with reduction gear.

### 2.3 Load remove precautions

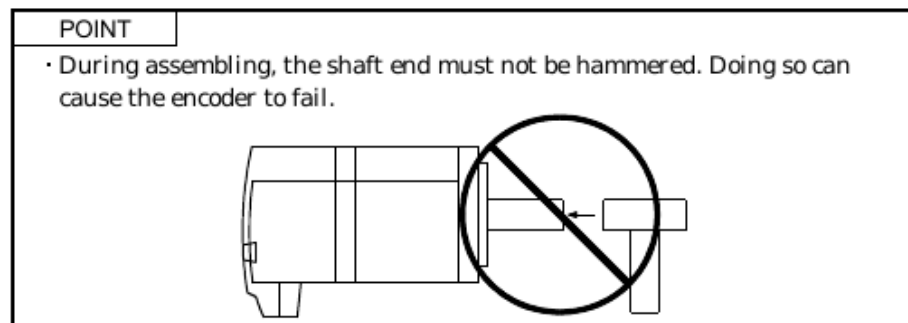

- When mounting a pulley to the servo motor shaft provided with a keyway, use the screw hole in the shaft end. To fit the pulley, first insert a double-end stud into the screw hole of the shaft, put a washer against the end face of the coupling, and insert and tighten a nut to force the pulley in.

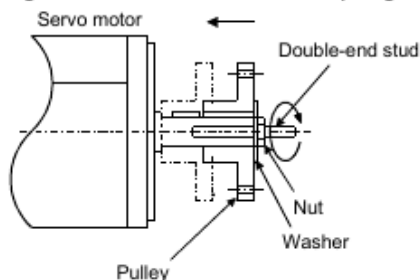

- For the servo motor shaft with a keyway, use the screw hole in the shaft end. For the shaft without a keyway, use a friction coupling or the like.
- When removing the pulley, use a pulley remover to protect the shaft from impact.
- To ensure safety, fit a protective cover or the like on the rotary area, such as the pulley, mounted to the shaft.
- When a threaded shaft end part is needed to mount a pulley on the shaft, please contact us.
- The orientation of the encoder on the servo motor cannot be changed.
- For installation of the servo motor, use spring washers, etc. and fully tighten the bolts so that they do not become loose due to vibration.
- For the HC-AQ series, use spring washers and apply Screw Lock to mount the servo motor. In addition, use Helisert screws when the flange for mounting the servo motor is made of aluminum.

## 2. INSTALLATION

### 2.4 Permissible load for the shaft

#### POINT

- Do not use a rigid coupling as it may apply excessive bending load to the shaft, leading to shaft breakage.

- Use a flexible coupling and make sure that the misalignment of the shaft is less than the permissible radial load.
- When using a pulley, sprocket or timing belt, select a diameter that will fit into the permissible radial load.
- Excess of the permissible load can cause the bearing life to reduce and the shaft to break.

#### 2.4.1 Without reduction gear

Servo Motor		(Note 1) L		Permissible Radial Load		Permissible Thrust Load	
		[mm]	[in]	[N]	[lb]	[N]	[lb]
HC-KF HC-KFS	053 / 13	25	0.98	88	20	59	13
	23 / 43	30	1.18	245	55	98	22
	(Note) 73	40	1.57	392	88	147	33
HC-MF HC-MFS	053 / 13	25	0.98	88	20	59	13
	23 / 43	30	1.18	245	55	98	22
	73	40	1.57	392	88	147	33
HA-FF	053	30	1.18	108	24	98	22
	13	30	1.18	118	27	98	22
	23 / 33	30	1.18	176	40	147	33
	43 / 63	40	1.57	323	73	284	64
HC-SF HC-SFS	81	55	2.17	980	220	490	110
	121 to 301	79	3.11	2058	463	980	220
	52 to 152	55	2.17	980	220	490	110
	202 / 702	79	3.11	2058	463	980	220
	53 to 153	55	2.17	980	220	490	110
HC-LFS	203 / 353	79	3.11	2058	463	980	220
	52 to 152	55	2.17	980	220	490	110
HC-RF HC-RFS	202/302	79	3.11	2058	463	980	220
	103 to 203	45	1.77	686	154	196	44
HC-UF HC-UFS	353 / 503	63	2.48	980	220	392	88
	72 / 152	55	2.17	637	143	490	110
	202	65	2.56	882	198	784	176
	352 / 502	65	2.56	1176	264	784	176
	13	25	0.98	88	20	59	13
	23 / 43	30	1.18	245	55	98	22
HA-LH	73	40	1.57	392	88	147	33
	11K 2	85	3.35	2450	551	980	220
	15K 2 / 22K 2	100	3.94	2940	661	980	220
HC-AQ	053/13	25	0.98	88	20	59	13
	0135	16	0.63	34	8	14	3
	0235	16	0.63	44	10	14	3
HA-LF	0335	16	0.63	49	11	14	3
	30K 2/37K 2/30K 24/ 37K 24	140	5.51	3234	727	1470	330
HA-LFS	45K 24 /55K 24	140	5.51	4900	1102	1960	441
	502/702/601/701M	85	3.35	2450	551	980	153
	801/11K 1M/12K 1/ 15K 1M	110	4.33	2940	661	980	153
	15K 1/22K 1M/20K 1/ 30K 1M/30K 2/37K 2	140	5.51	3234	727	1470	330
	25K 1/37K 1M/30K 1 37K 1	140	5.51	4900	1102	1960	441
	170	6.69	6370	1432	1960	441	

## 2. INSTALLATION

---

Note 1: For the symbols in the table, refer to the following diagram:

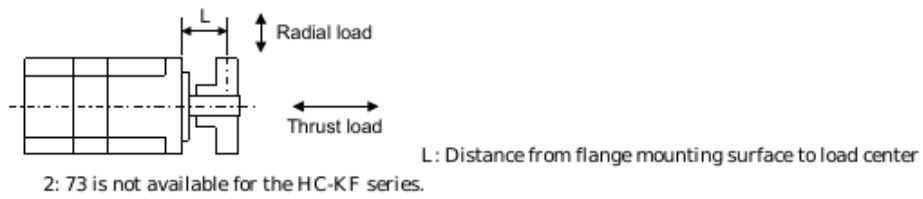

## 2. INSTALLATION

### 2.4.2 With reduction gear

The permissible radial loads in the table are the values at the center of the reduction gear output shaft.

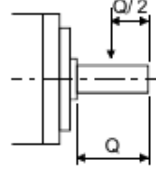

#### (1) HC-MF · HC-MFS · HC-KF · HC-KFS series

##### (a) General industrial machine-compliant

Item	Gear ratio	HC-MF(S)053(B)	HC-MF(S)13(B)	HC-MF(S)23(B)	HC-MF(S)43(B)	HC-MF(S)73(B)
		G1	G1	G1	G1	G1
		HC-KF(S)053(B)	HC-KF(S)13(B)	HC-KF(S)23(B)	HC-KF(S)43(B)	HC-KFS73(B)
		G1	G1	G1	G1	G1
Permissible Radial Load	[N]	1/5	150	330		430
		1/12	240	710		620
		1/20	370	780	760	970
	[lb]	1/5	34	74		97
		1/12	54	160		139
		1/20	83	175	171	218
Permissible Thrust Load	[N]	1/5	200	350		430
		1/12	320	720		620
		1/20	450	780	760	960
	[lb]	1/5	45	79		97
		1/12	72	162		139
		1/20	101	175	171	216

##### (b) Precision application-compliant

Item	Gear ratio	HC-MF(S)053(B)	HC-MF(S)13(B)	HC-MF(S)23(B)	HC-MF(S)43(B)	HC-MF(S)73(B)	
		G2	G2	G2	G2	G2	
		HC-KF(S)053(B)	HC-KF(S)13(B)	HC-KF(S)23(B)	HC-KF(S)43(B)	HC-KFS73(B)	
		G2	G2	G2	G2	G2	
Permissible Radial Load	[N]	1/5	160	160	160	340	390
		1/9	200	200	420	480	600
		1/20	260	540	610	790	1040
		1/29	290	610	700	900	1190
	[lb]	1/5	36	36	36	76	88
		1/9	45	45	94	108	135
		1/20	58	121	137	178	234
Permissible Thrust Load	[N]	1/5	220	220	220	370	390
		1/9	270	270	450	490	600
		1/20	400	660	640	790	1140
		1/29	450	750	830	1010	1290
	[lb]	1/5	49	49	49	83	87
		1/9	61	61	101	110	135
		1/20	90	148	144	178	256
	1/29	101	167	187	227	290	

## 2. INSTALLATION

### (2) HA-FF series

#### (a) General industrial machine-compliant

Item	Gear ratio	HA-FF053(B)G1	HA-FF13(B)G1	HA-FF23(B)G1	HA-FF33(B)G1	HA-FF43(B)G1	HA-FF63(B)G1
Permissible Radial Load	[N]	1/5	588	686	686	980	
		1/10	588	686	686	1470	
		1/20	588	1176	1568	1764	
		1/30	686	1225	1764	2156	
	[lb]	1/5	132	154	154	220	
		1/10	132	154	154	330	
		1/20	132	264	353	397	
		1/30	154	275	397	485	

#### (b) Precision application-compliant

Item	Gear ratio	HA-FF053(B)G2	HA-FF13(B)G2	HA-FF23(B)G2	HA-FF33(B)G2	HA-FF43(B)G2	HA-FF63(B)G2	
Permissible Radial Load	[N]	1/5	69	69	98	216	216	588
		1/9					735	735
		1/10	88	127	265	265		
		1/15	137	216	392			
		1/20			980	980	1274	1274
		1/25	392	784				
		1/29			1078	1470	1470	1470
		1/45		1274	1666	1666	1666	3430
	[lb]	1/5	15	15	22	49	49	132
		1/9					165	165
		1/10	20	29	60	60		
		1/15	31	49	88			
		1/20			220	220	286	286
		1/25	88	176				
		1/29			242	330	330	330
		1/45		286	375	375	375	771
Permissible Thrust Load	[N]	1/5	59	59	147	265	265	784
		1/9					980	980
		1/10	78	167	343	343		
		1/15	88	216	363			
		1/20			1372	1372	2254	2254
		1/25	314	412				
		1/29			1764	2548	2548	2548
		1/45		1960	3234	3234	3234	5390
	[lb]	1/5	13	13	33	60	60	176
		1/9					220	220
		1/10	16	38	77	77		
		1/15	20	49	82			
		1/20			308	308	507	507
		1/25	71	93				
		1/29			397	573	573	573
		1/45		441	727	727	727	1212



## 2. INSTALLATION

### (3) HC-SF · HC-SFS (2000r/min) series

#### (a) General industrial machine-compliant

Item	Gear ratio	HC-SF(S)52(B) G1	HC-SF(S)102(B) G1	HC-SF(S)152(B) G1	HC-SF(S)202(B) G1	HC-SF(S)352(B) G1	HC-SF(S)502(B) G1	HC-SF(S)702(B) G1
Permissible Radial Load	[N]	1/6	2058	2842	2842	2842	3332	
		1/11	2391	3273	3273	3273	3871	5488
		1/17	2832	3646	3646	3646	4420	6468
		1/29	3273	4410	5135	7291	7291	13426
		1/35	5253	5253	6047	8555	8555	16072
		1/43	5253	6047	8555	8555	11662	16072
		1/59	5800	9741	9741	9741	13132	
	[lb]	1/6	463	639	639	639	749	
		1/11	538	728	728	728	870	1234
		1/17	637	820	820	820	994	1454
		1/29	728	991	1154	1639	1639	3018
		1/35	1181	1181	1359	1923	1923	3613
		1/43	1181	1359	1923	1923	2622	3613
		1/59	1304	2190	2190	2190	2952	
Permissible Thrust Load	[N]	1/6	1470	2352	2352	2352	3920	
		1/11	1470	2764	2764	2764	3920	6292
		1/17	1470	2940	2940	2940	3920	6860
		1/29	1470	2940	3920	6860	6860	13720
		1/35	2940	2940	3920	6860	6860	13720
		1/43	2940	3920	6860	6860	9800	13720
		1/59	2940	6860	6860	6860	9800	
	[lb]	1/6	330	529	529	529	881	
		1/11	330	621	621	621	881	1415
		1/17	330	661	661	661	881	1542
		1/29	330	661	881	1542	1542	3084
		1/35	661	661	881	1542	1542	3084
		1/43	661	881	1542	1542	2203	3084
		1/59	661	1542	1542	1542	2203	

## 2. INSTALLATION

### (b) Precision application-compliant

Item	Gear ratio	HC-SF(S)52(B)	HC-SF(S)102(B)	HC-SF(S)152(B)	HC-SF(S)202(B)	HC-SF(S)352(B)	HC-SF(S)502(B)	HC-SF(S)702(B)	
		G2	G2	G2	G2	G2	G2	G2	
Permissible Radial Load	[N]	1/5	833	833	833	1666	3822	3822	3822
		1/9	980	980	1960	1960	4704	4704	
		1/20	1274	2646	2646	6076	6076		
		1/29	2940	2940	6860	6860			
		1/45	3430	8036	8036	8036			
	[lb]	1/5	187	187	187	375	859	859	859
		1/9	220	220	441	441	1058	1058	
		1/20	286	595	595	1366	1366		
		1/29	661	661	1542	1542			
		1/45	771	1807	1807	1807			
Permissible Thrust Load	[N]	1/5	1176	1176	1176	2156	5488	5488	5488
		1/9	1568	1568	2646	2646	7252	7252	
		1/20	2254	3724	3724	9506	9506		
		1/29	4704	4704	11760	11760			
		1/45	5390	14700	14700	14700			
	[lb]	1/5	264	264	264	485	1234	1234	1234
		1/9	353	353	595	595	1630	1630	
		1/20	507	837	837	2137	2137		
		1/29	1058	1058	2644	2644			
		1/45	1212	3305	3305	3305			

### (4) HC-RF • HC-RFS series

Item	Gear ratio	HC-RF(S)103(B)	HC-RF(S)153(B)	HC-RF(S)203(B)	HC-RF(S)353(B)	HC-RF(S)503(B)	
		G2	G2	G2	G2	G2	
Permissible Radial Load	[N]	1/5	833	833	833	1666	3822
		1/9	980	1960	1960	4704	4704
		1/20	2646	2646	2646	6076	6076
		1/29	2940	2940	6860	6860	
		1/45	3430	8036	8036		
	[lb]	1/5	187	187	187	375	859
		1/9	220	441	441	1058	1058
		1/20	595	595	595	1366	1366
		1/29	661	661	1542	1542	
		1/45	771	1806	1806		
Permissible Thrust Load	[N]	1/5	1176	1176	1176	2156	5488
		1/9	1568	2646	2646	7252	7252
		1/20	38.8	3724	3724	9506	9506
		1/29	4704	4704	11760	11760	
		1/45	5390	14700	14700		
	[lb]	1/5	264	264	264	485	1234
		1/9	353	595	595	1630	1630
		1/20	8.7	837	837	2137	2137
		1/29	1058	1058	2644	2644	
		1/45	1212	3305	3305		

## 2. INSTALLATION

### 2.5 Protection from oil and water

- (1) Next, the servo motor is not waterproof (IP44). Do not subject the servo motor to oil and water. Especially for the HC-MF · HC-KF · HC-AQ · HC-KFS · HC-MFS and HA-FF series, do not subject the shaft-through portion to oil.

Servo Motor Series	Protection
HC-KF/HC-MF HA-LF/HA-FF/HA-LFS	IP44
HC-AQ/HC-KFS/HC-MFS	IP55
HA-LH	JP44

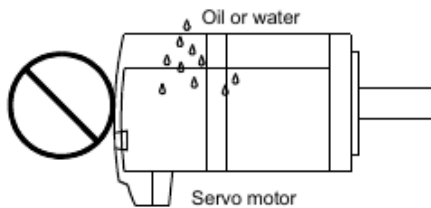

- (2) When the gear box is mounted horizontally, the oil level in the gear box should always be lower than the oil seal lip on the servo motor shaft. If it is higher than the oil seal lip, oil will enter the servo motor, leading to a fault.

The HC-MF · HC-KF · HC-AQ · HC-MFS and HC-KFS series servo motor is not equipped with an oil seal and cannot be used with the gear box as described above. Oil should be shut off on the gear box side.

In a special specification article with an oil seal is available. Please contact Mitsubishi.

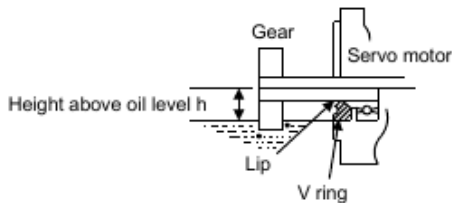

Servo Motor		Height above Oil Level h	
		[mm]	[in]
HC-SF HC-SFS	81	20	0.79
	121 to 1	25	0.98
	52 to 2	20	0.79
	202 to 2	25	0.98
	53 to 3	20	0.79
	203/353	25	0.98
HC-LFS	52 to 2	20	0.79
	202/302	25	0.98
HC-RF HC-RFS	103 to 3	20	0.79
	72/152	20	0.79
HC-UF HC-UFS	202 to 2	25	0.98
	13	12	0.47
	23/43	14	0.55
	73	20	0.79

Servo Motor		Height above Oil Level h	
		[mm]	[in]
HA-FF	053/13	8	0.32
	23/33	12	0.47
	43/63	14	0.55
HA-LH	11K2	30	0.18
	15K2/22K2	40	1.58
HA-LF	30K2/37K2/30K24/ 37K24	45	1.77
	45K24/55K24	48	1.89
HA-LFS	601/701M/11K2 502/702	34	1.34
	15K1/22K1M/30K2/ 20K1/30K1M/37K2	45	1.77
	801/12K1/25K1/ 30K1/11K1M/15K1M/ 37K1M/15K2/22K2	48	1.89
	37K1	55	2.17

## 2. INSTALLATION

---

- (3) When installing the servo motor horizontally, face the power cable and encoder cable downward. When installing the servo motor vertically or obliquely, provide a trap for the cable.

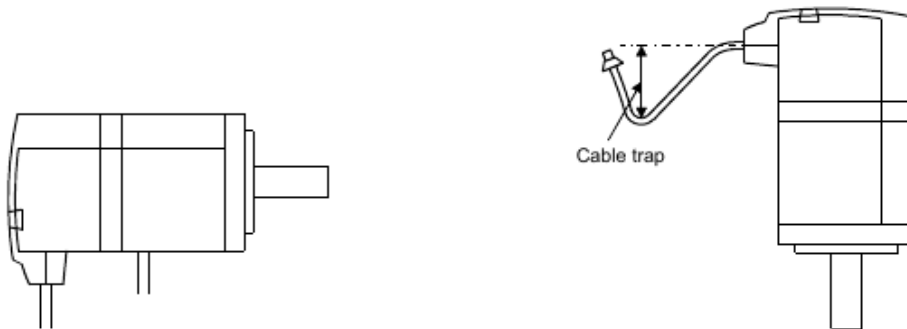

- (4) Do not use the servo motor with its cable soaked in oil or water. (Figure on the right)

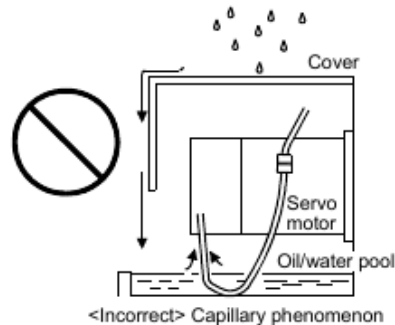

- (5) When the servo motor is to be installed with the shaft end at top, provide measures so that it is not exposed to oil and water entering from the machine side, gear box, etc.

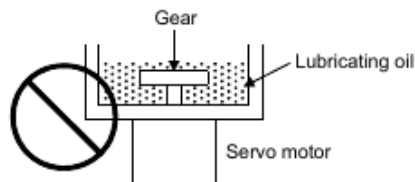

- (6) If the servo motor is exposed to oil such as coolant, the sealant, packing, cable and others may be affected depending on the oil type.
- (7) In the environment where the servo motor is exposed to oil mist, oil, water and/or like, the servo motor of the standard specifications may not be usable. Contact us.
- (8) In the case of the servo motor with oil seal, the oil seal may sound during operation. It poses no problems in function.

## 2. INSTALLATION

---

### 2.6 Cooling fan

The HA-LH · HA-LF and HA-LFS servo motors have a cooling fan. Leave the following distance between the servo motor's suction face and the wall.

Servo Motor Series	Distance L	
	[mm]	[in]
HA-LH series	50	1.97
HA-LFS601 to 12K1 701M to 15K1M 11K2 to 22K2	100	3.94
HA-LF 30K2/37K2 HA-LF 30K24 to 55K24 HA-LFS15K1/20K1/22K1M/ 30K1M/37K2/30K2	150	5.91

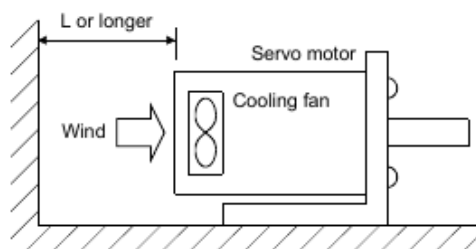

### 2.7 Cable

The power supply and encoder cables routed from the servo motor should be fixed to the servo motor to keep them unmovable. Otherwise, cable breaks may occur. In addition, do not modify the connectors, terminals and others at the ends of the cables.

### 3. CONNECTORS USED FOR SERVO MOTOR

#### 3. CONNECTORS USED FOR SERVO MOTOR WIRING

##### 3.1 Makeups

This section gives connector makeups on an operating environment basis. Use the models of the manufacturers given or equivalent.

##### 3.1.1 HC-KF(-UE) · HC-MF(-UE) · HA-FF · HC-UF3000r/min series

Use round crimping terminals (1.25-4) for connection of the power supply and electromagnetic brake. For connection of the encoder, use the connector indicated in this section or equivalent. This connector may be used with the EN Standard and UL/C-UL Standard but is not waterproof.

Servo Motor	Connector Supplied for Servo Motor (AMP)	Cable Side Connector		
		Housing (AMP)	Connector Pin (AMP)	Cable Clamp (Toa Electric Industry)
HC-KF□ (B) HC-KF□ (B)-UE HC-MF□ (B) HC-MF□ (B)-UE HA-FF□ (B) HC-UF13 to 73(B)	1-172169-9	1-172161-9	170359-1 170363-1 (loose piece)	MTI-0002

##### 3.1.2 HA-FF□C-UE series

If used with a waterproof connector, the HA-FF□C(B)-UE does not improve in ingress protection (IP54).

(1) Non-waterproof, UL/C-UL Standard-compliant

(a) When using cabletyre cables

1) For connection of power supply

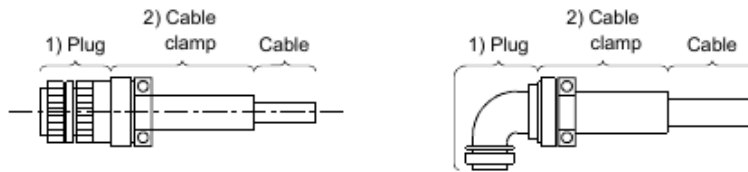

Servo Motor	Connector Supplied for Servo Motor	Cable Side Connector		
		1) Plug (DDK)		2) Cable clamp (DDK)
		Type	Model	
HA-FF□C(B)-UE	CE05-2A14S-2PD-B	Straight	MS3106B14S-2S	MS3057-6A
		Angle	MS3108B14S-2S	

### 3. CONNECTORS USED FOR SERVO MOTOR

#### 2) For connection of encoder

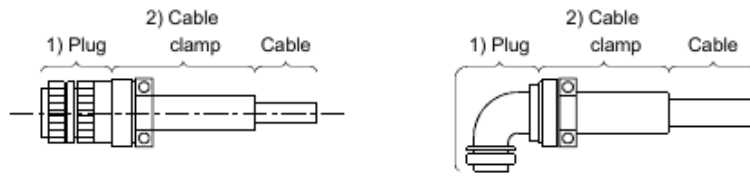

Servo Motor	Connector Supplied for Servo Motor	Cable Side Connector		
		1) Plug (DDK)		2) Cable clamp (DDK)
		Type	Model	
HA-FF□C(B)-UE	MS3102A20-29P	Straight	MS3106B20-29S	MS3057-12A
		Angle	MS3108B20-29S	

#### 3) For connection of brake

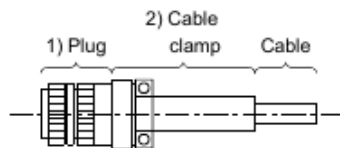

Servo Motor	Connector Supplied for Servo Motor	Cable Side Connector		
		Plug (DDK)		2) Cable clamp (DDK)
		Type	Model	
HA-FF□C(B)-UE	MS3102A10SL-4P	Straight	MS3106A10SL-4S	MS3057-4A

#### (b) When using flexible conduits

##### 1) For connection of power supply

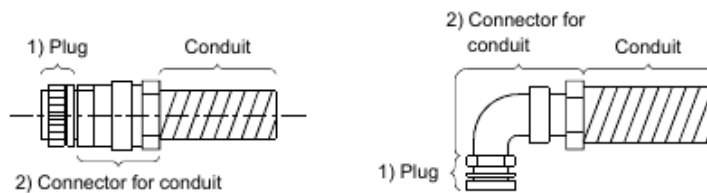

Servo Motor	Connector Supplied for Servo Motor	1) Plug (DDK)	Cable Side Connector					Conduit	
			2) Cable Connector					Model	ID
			Type	Maker	Size	Model			
HA-FF□C(B)-UE	CE05-2A14S-2PD-B	MS3106A14S-2S(D190)	Straight	Nippon flex	1/4	RCC-102RL-MS14F	VF-02	8.3	
					3/8	RCC-103RL-MS14F	VF-03	10.6	
					1/2	RCC-104RL-MS14F	VF-04	14.0	
				Daiwa Dengyo	10	MSA-10-14	FCV10	10.0	
					12	MSA-12-14	FCV12	12.3	
					Angle	Nippon flex	1/4	RCC-302RL-MS14F	VF-02
			3/8	RCC-303RL-MS14F			VF-03	10.6	
			1/2	RCC-304RL-MS14F			VF-04	14.0	
			Daiwa Dengyo	10		MAA-10-14	FCV10	10.0	
				12	MAA-12-14	FCV12	12.3		

### 3. CONNECTORS USED FOR SERVO MOTOR

#### 2) For connection of encoder

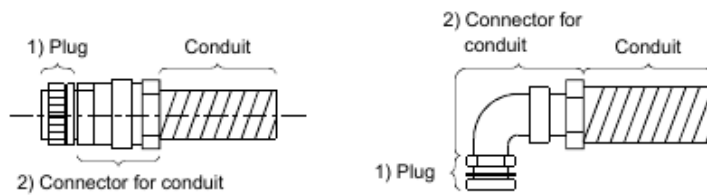

Servo Motor	Connector Supplied for Servo Motor	Cable Side Connector						
		1) Plug (DDK)	2) Cable Connector				Conduit	
			Type	Maker	Size	Model	Model	ID
HA-FF□C(B)-UE	MS3102A20-29P	MS3106A20-29S(D190)	Straight	Nippon flex	1/2	RCC-104RL-MS20F	VF-04	14.0
					3/4	RCC-106RL-MS20F	VF-06	19.0
				Daiwa Dengyo	16	MSA-16-20	FCV16	15.8
					22	MSA-22-20	FCV22	20.8
			Angle	Nippon flex	1/2	RCC-304RL-MS20F	VF-04	14.0
					3/4	RCC-306RL-MS20F	VF-06	19.0
				Daiwa	16	MAA-16-20	FCV16	15.8
				Dengyo	22	MAA-22-20	FCV22	20.8

#### 3) For connection of brake

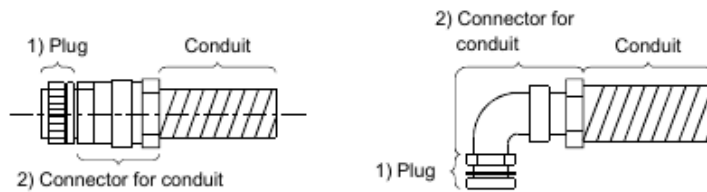

Servo Motor	Connector Supplied for Servo Motor	Cable Side Connector						
		1) Plug (DDK)	2) Cable Connector				Conduit	
			Type	Maker	Size	Model	Model	ID
HA-FF□C(B)-UE	MS3102A10SL-4P	MS3106A10SL-4S(D190)	Straight	Nippon flex	1/4	RCC-102RL-MS10F	VF-02	8.3
				Daiwa Dengyo	10	MSA-10-10	FCV10	10.0
			Angle	Nippon flex	1/4	RCC-302RL-MS10F	VF-02	8.3
				Daiwa Dengyo	10	MAA-10-10	FCV10	10.0



### 3. CONNECTORS USED FOR SERVO MOTOR

(2) EN Standard, UL/C-UL Standard-compliant

(a) When using cabtyre cables

1) For connection of power supply

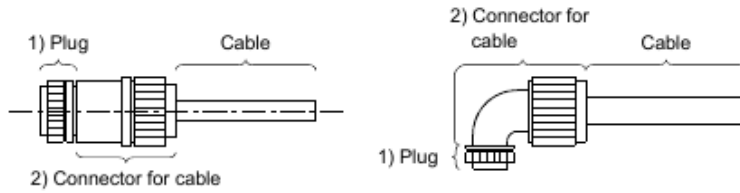

Servo Motor	Connector Supplied for Servo Motor	Cable Side Connector				
		1) Plug (DDK)	2) Connector for Cable			
			Type	Maker	Cable OD	Model
HA-FF□C(B)-UE	CE05-2A14S-2PD-B	CE05-6A14S-2SD-B	Straight	Nippon flex	4 to 8	ACS-08RL-MS14F
				Nippon flex	8 to 12	ACS-12RL-MS14F
				Daiwa Dengyo	5 to 8.3	YSO14-5 to 8
			Daiwa Dengyo	8.3 to 11.3	YSO14-9 to 11	
			Angle	Nippon flex	4 to 8	ACA-08RL-MS14F
				Nippon flex	8 to 12	ACA-12RL-MS14F
Daiwa Dengyo	5 to 8.3	YLO14-5 to 8				
Daiwa Dengyo	8.3 to 11.3	YLO14-9 to 11				

2) For connection of encoder

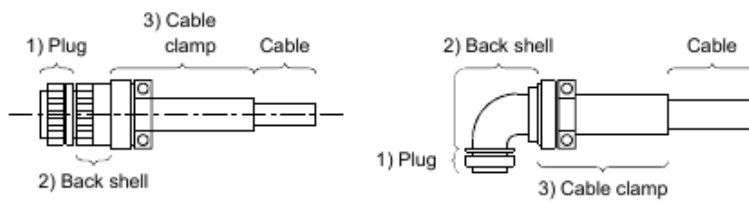

Servo Motor	Connector Supplied for Servo Motor	Cable Side Connector				
		1) Plug (DDK)	2) Back Shell (DDK)		3) Cable Clamp (DDK)	
			Type	Model	Cable OD	Model
HA-FF□C(B)-UE	MS3102A20-29P	MS3106A20-29S(D190)	Straight	CE02-20BS-S	6.8 to 10	CE3057-12A-3
			Angle	CE-20BA-S		

### 3. CONNECTORS USED FOR SERVO MOTOR

#### 3) For connection of brake

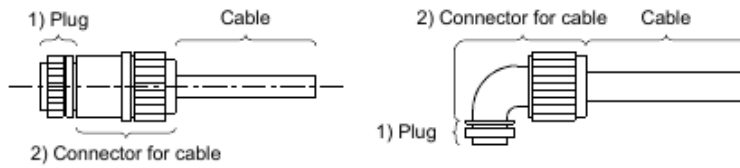

Servo Motor	Connector Supplied for Servo Motor	Cable Side Connector				
		1) Plug (DDK)	2) Cable Connector			
			Type	Maker	Cable OD	Model
HA-FF□C(B)-UE	MS3102A10SL-4P	MS3106A10SL-4S(D190)	Straight	Nippon flex	4 to 8	ACS-08RL-MS10F
					8 to 12	ACS-12RL-MS10F
				Daiwa Dengyo	5 to 8.3	YS010-5 to 8
			Angle	Nippon flex	4 to 8	ACA-08RL-MS10F
					8 to 12	ACA-12RL-MS10F
				Daiwa Dengyo	5 to 8.3	YL010-5 to 8

#### (b) When using flexible conduits

##### 1) For connection of power supply

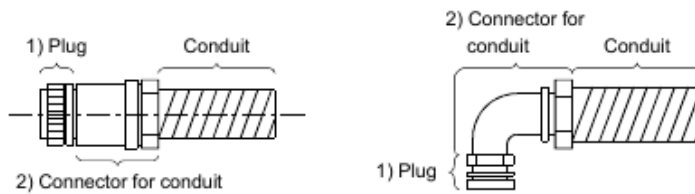

Servo Motor	Connector Supplied for Servo Motor	Cable Side Connector						
		1) Plug (DDK)	2) Cable Connector				Conduit	
			Type	Maker	Size	Model	Model	ID
HA-FF□C(B)-UE	CE05-2A14S-2PD-B	CE05-6A14S-2SD-B	Straight	Nippon flex	1/4	RCC-102RL-MS14F	VF-02	8.3
					3/8	RCC-103RL-MS14F	VF-03	10.6
					1/2	RCC-104RL-MS14F	VF-04	14.0
				Daiwa Dengyo	10	MSA-10-14	FCV10	10.0
					12	MSA-12-14	FCV12	12.3
					Angle	Nippon flex	1/4	RCC-302RL-MS14F
			3/8	RCC-303RL-MS14F			VF-03	10.6
			1/2	RCC-304RL-MS14F			VF-04	14.0
			Daiwa Dengyo	10		MAA-10-14	FCV10	10.0
				12		MAA-12-14	FCV12	12.3

### 3. CONNECTORS USED FOR SERVO MOTOR

#### 2) For connection of encoder

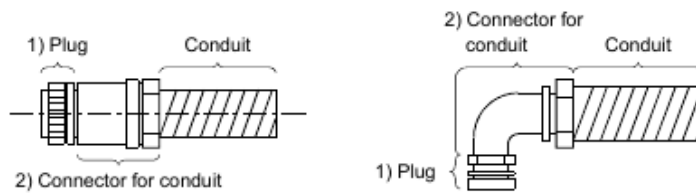

Servo Motor	Connector Supplied for Servo Motor	Cable Side Connector						
		1) Plug (DDK)	2) Cable Connector				Conduit	
			Type	Maker	Size	Model	Model	ID
HA-FF□C(B)-UE	MS3102A20-29P	MS3106A20-29S(D190)	Straight	Nippon flex	1/2	RCC-104RL-MS20F	VF-04	14.0
					3/4	RCC-106RL-MS20F	VF-06	19.0
				Daiwa Dengyo	16	MSA-16-20	FCV16	15.8
					22	MSA-22-20	FCV22	20.8
			Angle	Nippon flex	1/2	RCC-304RL-MS20F	VF-04	14.0
					3/4	RCC-306RL-MS20F	VF-06	19.0
				Daiwa Dengyo	16	MAA-16-20	FCV16	15.8
					22	MAA-22-20	FCV22	20.8

#### 3) For connection of brake

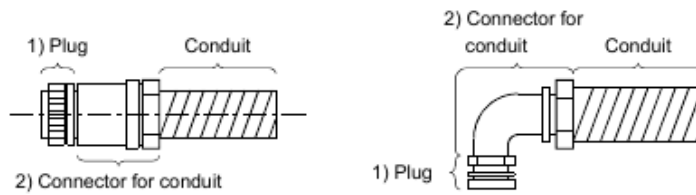

Servo Motor	Connector Supplied for Servo Motor	Cable Side Connector						
		1) Plug (DDK)	2) Cable Connector				Conduit	
			Type	Maker	Size	Model	Model	ID
HA-FF□C(B)-UE	MS3102A10SL-4P	MS3106A10-SL-4S(D190)	Straight	Nippon flex	1/4	RCC-102RL-MS10F	VF-02	8.3
				Daiwa Dengyo	10	MSA-10-10	FCV10	10.0
			Angle	Nippon flex	1/4	RCC-302RL-MS10F	VF-02	8.3
				Daiwa Dengyo	10	MAA-10-10	FCV10	10.0

### 3. CONNECTORS USED FOR SERVO MOTOR

#### 3.1.3 HC-SF(S) · HC-RF(S) · HC-UF(S)2000r/min, HA-LH · HA-LF · HA-LFS · HC-LFS series

(1) Non-waterproof, UL/C-UL Standard-compliant

(a) When using cabtyre cables

1) For connection of power supply

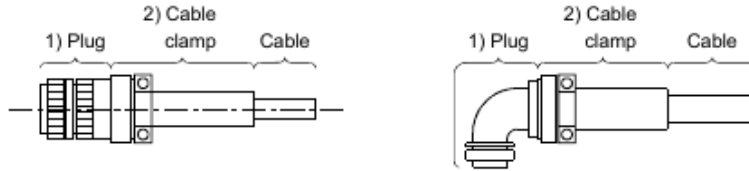

Servo Motor	Connector Supplied for Servo Motor	Cable Side Connector		
		1) Plug (DDK)		2) Cable clamp (DDK)
		Type	Model	
HC-SF 81(B) HC-SF 52(B) to 152(B) HC-SF 53(B) to 153(B) HC-RF 103(B) to 203(B) HC-UF 72(B) · 152(B) HC-SF 581(B) HC-SF 552(B) to 152(B) HC-SF 553(B) to 153(B) HC-RF 5103(B) to 203(B) HC-UF 572(B) · 152(B) HC-LF 552(B) to 152(B)	CE05-2A22-23PD-B	Straight          Angle	MS3106B22-23S          MS3108B22-23S	MS3057-12A
HC-SF 121(B) to 301(B) HC-SF 202(B) to 502(B) HC-SF 203(B) · 353(B) HC-RF 353(B) to 503(B) HC-UF 202(B) to 502(B) HC-SF 5121(B) to 301(B) HC-SF 5202(B) to 502(B) HC-SF 5203(B) to 353(B) HC-RF 5353(B) · 503(B) HC-UF 5202(B) to 502(B) HA-LF 5502 HC-LF 5202(B) · 302(B)	CE05-2A24-10PD-B	Straight          Angle	MS3106B24-10S          MS3108B24-10S	MS3057-16A
HC-SF 702 HC-SF 5702(B) HA-LF 5702	CE05-2A32-17PD-B	Straight  Angle	MS3106B32-17S  MS3108B32-17S	MS3057-20A

### 3. CONNECTORS USED FOR SERVO MOTOR

#### 2) For connection of encoder

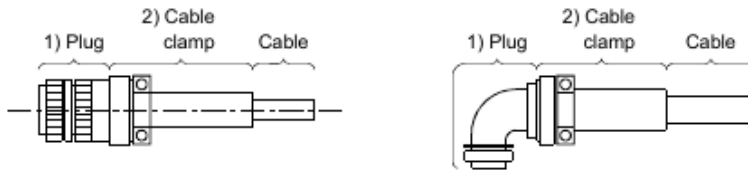

Servo Motor	Connector Supplied for Servo Motor	Cable Side Connector		
		1) Plug (DDK)		2) Cable clamp (DDK)
		Type	Model	
HC-SF 81(B) to 301(B) HC-SF 52(B) to 702(B) HC-SF 53(B) to 353(B) HC-RF 103(B) to 503(B) HC-UF 72(B) to 502(B) HC-SF 581(B) to 301(B) HC-SF 552(B) to 702(B) HC-SF 553(B) to 353(B) HC-RF 5103(B) to 503(B) HC-UF 572(B) to 502(B) HA-LH 11K 2 to HA-LH 22K 2 HA-LF 30K 24 to HA-LF 55K 24 HA-LF 30K 2 · 37K 2 HA-LF 5601 to 37K 1 HA-LF 5701M to 37K 1 HA-LF 5502 to 37K 2 HC-LF 552(B) to 302(B)	MS3102A20-29P	Straight           Angle	MS3106B20-29S           MS3108B20-29S	MS3057-12A

#### 3) For connection of brake

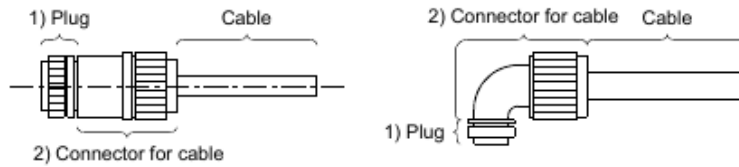

Servo Motor	Connector Supplied for Servo Motor	Cable Side Connector				
		1) Plug (DDK)	2) Connector for Cable			
			Type	Maker	Cable OD	Model
HC-SF 121(B) to 301(B) HC-SF 202(B) to 502(B) HC-SF 203(B) · 353(B) HC-UF 202(B) to 502(B) HC-SF 5121(B) to 301(B) HC-SF 5202(B) to 502(B) HC-SF 5203(B) · 353(B) HC-UF 5202(B) to 502(B) HC-LF 5202(B) · 302(B)	MS3102A10SL-4P	MS3106A10SL-4S	Straight    Angle	Nippon flex  Daiwa Dengyo  Nippon flex  Daiwa Dengyo	4 to 8 8 to 12 5 to 8.3 4 to 8 8 to 12 5 to 8.3	ACS-08RL-MS10F ACS-12RL-MS10F YSO10-5 to 8 ACA-08RL-MS10F ACA-12RL-MS10F YLO10-5 to 8

### 3. CONNECTORS USED FOR SERVO MOTOR

(b) When using flexible conduits

1) For connection of power supply

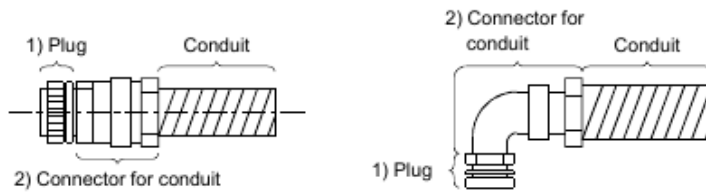

Servo Motor	Connector Supplied for Servo Motor	Cable Side Connector						
		1) Plug (DDK)	2) Connector for conduit				Conduit	
			Type	Maker	Size	Model	Model	ID
HC-SF 81(B) HC-SF 52(B) to 152(B) HC-SF 53(B) to 153(B) HC-RF 103(B) to 203(B) HC-UF 72(B) · 152(B) HC-SF 581(B) HC-SF 552(B) to 152(B) HC-SF 553(B) to 153(B) HC-RF S103(B) to 203(B) HC-UF S72(B) · 152(B) HC-LF S52(B) to 152(B)	CE 05-2A22-23PD-B	MS3106A22-23S(D190)	Straight	Nippon flex	1/2	RCC-104RL-MS22F	VF-04	14.0
					3/4	RCC-106RL-MS22F	VF-06	19.0
					1	RCC-108RL-MS22F	VF-08	24.4
				Daiwa Dengyo	16	MSA-16-22	FCV16	15.8
					22	MSA-22-22	FCV22	20.8
					28	MSA-28-22	FCV28	26.4
			Angle	Nippon flex	1/2	RCC-304RL-MS22F	VF-04	14.0
					3/4	RCC-306RL-MS22F	VF-06	19.0
					1	RCC-308RL-MS22F	VF-08	24.4
				Daiwa Dengyo	16	MAA-16-22	FCV16	15.8
					22	MAA-22-22	FCV22	20.8
					28	MAA-28-22	FCV28	26.4
HC-SF 121(B) to 301(B) HC-SF 202(B) to 502(B) HC-SF 203(B) · 352(B) HC-RF 353(B) to 503(B) HC-UF 202(B) to 502(B) HC-SF S121(B) to 301(B) HC-SF S202(B) to 502(B) HC-SF S203(B) to 353(B) HC-RF S353(B) · 503(B) HC-UF S202(B) to 502(B) HA-LF S502 HC-LF S202(B) · 302(B)	CE 05-2A24-10PD-B	MS3106A24-10S(D190)	Straight	Nippon flex	1/2	RCC-104RL-MS24F	VF-04	14.0
					3/4	RCC-106RL-MS24F	VF-06	19.0
					1	RCC-108RL-MS24F	VF-08	24.4
				Daiwa Dengyo	16	MSA-16-24	FCV16	15.8
					22	MSA-22-24	FCV22	20.8
					28	MSA-28-24	FCV28	26.4
			Angle	Nippon flex	1/2	RCC-304RL-MS24F	VF-04	14.0
					3/4	RCC-306RL-MS24F	VF-06	19.0
					1	RCC-308RL-MS24F	VF-08	24.4
				Daiwa Dengyo	16	MAA-16-24	FCV16	15.8
					22	MAA-22-24	FCV22	20.8
					28	MAA-28-24	FCV28	26.4
HC-SF 702(B) HC-SF S702(B) HA-LF S702	CE 05-2A32-17PD-B	MS3106A32-17S(D190)	Straight	Nippon flex	3/4	RCC-106RL-MS32F	VF-06	19.0
					1	RCC-108RL-MS32F	VF-08	24.4
			Angle	Daiwa Dengyo	3/4	RCC-306RL-MS32F	VF-06	19.0
					1	RCC-308RL-MS32F	VF-08	24.4

### 3. CONNECTORS USED FOR SERVO MOTOR

#### 2) For connection of encoder

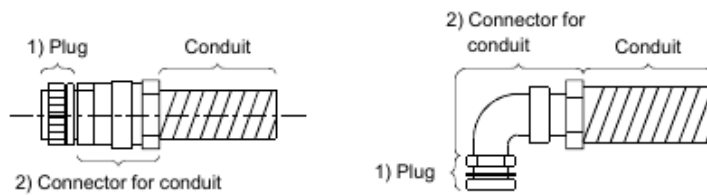

Servo Motor	Connector Supplied for Servo Motor	Cable Side Connector						
		1) Plug (DDK)	2) Connector for conduit				Conduit	
			Type	Maker	Size	Model	Model	ID
HC-SF 81(B) to 301(B) HC-SF 52(B) to 702(B) HC-SF 53(B) to 353(B) HC-RF 103(B) to 503(B) HC-UF 72(B) to 502(B) HC-SF 581(B) to 301(B) HC-SF 552(B) to 702(B) HC-SF 553(B) to 353(B) HC-RF 5103(B) to 503(B) HC-UF 572(B) to 502(B) HA-LH 11K 2 to 22K 2(B) HA-LF 30K 24 to 55K 24 HA-LF 30K 2 · 37K 2 HA-LF 5601 to 37K 1 HA-LF 5701M to 37K 1M HA-LF 5502 to 37K 2 HC-LF 552(B) to 302(B)	MS3102A20-29P	MS3106A20-29S(D190)	Straight	Nippon flex	1/2	RCC-104RL-MS20F	VF-04	14.0
					3/4	RCC-106RL-MS20F	VF-06	19.0
				Daiwa Dengyo	16	MSA-16-20	FCV16	15.8
					22	MSA-22-20	FCV22	20.8
			Angle	Nippon flex	1/2	RCC-304RL-MS20F	VF-04	14.0
					3/4	RCC-306RL-MS20F	VF-06	19.0
				Daiwa Dengyo	16	MAA-16-20	FCV16	15.8
					22	MAA-22-20	FCV22	20.8

#### 3) For connection of brake

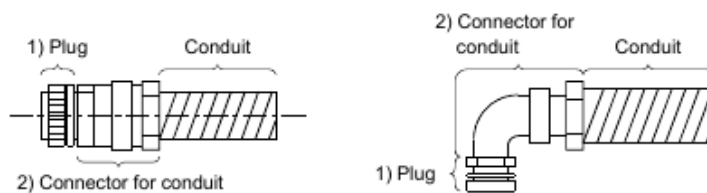

Servo Motor	Connector Supplied for Servo Motor	Cable Side Connector						
		1) Plug (DDK)	2) Connector for conduit				Conduit	
			Type	Maker	Size	Model	Model	ID
HC-SF 121(B) to 301(B) HC-SF 202(B) to 502(B) HC-SF 203(B) · 353(B) HC-UF 202(B) to 502(B) HC-SF 5121(B) to 301(B) HC-SF 5202(B) to 502(B) HC-SF 5203(B) · 353(B) HC-UF 5202(B) to 502(B) HC-LF 5202(B) · 302(B)	MS3102A10SL-4P	MS3106A10SL-4S(D190)	Straight	Nippon flex	1/4	RCC-102RL-MS10F	VF-02	8.3
				Daiwa Dengyo	10	MSA-10-10	FCV10	10
			Angle	Nippon flex	1/4	RCC-302RL-MS10F	VF-02	8.3
				Daiwa Dengyo	10	MAA-10-10	FCV10	10

### 3. CONNECTORS USED FOR SERVO MOTOR

(2) Waterproof (IP65), EN Standard, UL/C-UL Standard-compliant

(a) When using cable cables

1) For connection of power supply

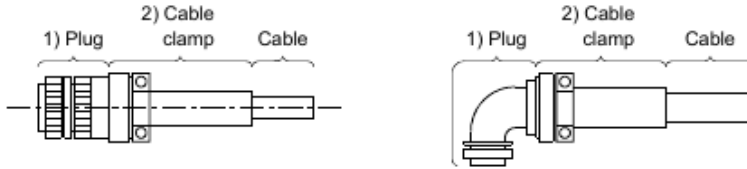

Servo Motor	Connector Supplied for Servo Motor	Cable Side Connector			
		1) Plug (DDK)		2) Cable clamp (DDK)	
		Type	Model	Cable OD	Model
HC-SF 81(B) HC-SF 52(B) to 152(B) HC-SF 53(B) to 153(B) HC-RF 103(B) to 203(B) HC-UF 72(B) · 152(B) HC-SF 581(B) HC-SF 552(B) to 152(B) HC-SF 553(B) to 153(B) HC-RF 5103(B) to 203(B) HC-UF 572(B) · 152(B) HC-LF 552(B) to 152(B)	CE 05-2A22-23PD-B	Straight	CE 05-6A22-23SD-B-BSS	9.5 to 13	CE 3057-12A-2(D265)
	Angle	CE 05-8A22-23SD-B-BAS	12.5 to 16	CE 3057-12A-1(D265)	
HC-SF 121(B) to 301(B) HC-SF 202(B) to 502(B) HC-SF 203(B) · 353(B) HC-RF 353(B) to 503(B) HC-UF 202(B) to 502(B) HC-SF 5121(B) to 301(B) HC-SF 5202(B) to 502(B) HC-SF 5203(B) · 353(B) HC-RF 5353(B) · 503(B) HC-UF 5202(B) to 502(B) HA-LF 5502 HC-LF 5202(B) · 302(B)	CE 05-2A24-10PD-B	Straight	CE 05-6A24-10SD-B-BSS	13 to 15.5	CE 3057-16A-2(D265)
	Angle	CE 05-8A24-10SD-B-BAS	15 to 19.1	CE 3057-16A-1(D265)	
HC-SF 702(B) HC-SF 5702(B) HA-LF 5702	CE 05-2A32-17PD-B	Straight	CE 05-6A32-17SD-B-BSS	22 to 23.8	CE 3057-20A-1(D265)
	Angle	CE 05-8A32-17SD-B-BAS			



### 3. CONNECTORS USED FOR SERVO MOTOR

#### 2) For connection of encoder

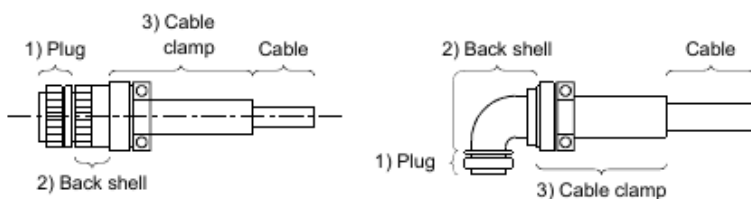

Servo Motor	Connector Supplied for Servo Motor	Cable Side Connector				
		1) Plug (DDK)	2) Back shell		3) Cable clamp (DDK)	
			Type	Model	Cable OD	Model
HC-SF 81(B) to 301(B) HC-SF 52(B) to 702(B) HC-SF 53(B) to 353(B) HC-RF 103(B) to 503(B) HC-UF 72(B) to 502(B) HC-SF 581(B) to 301(B) HC-SF 552(B) to 702(B) HC-SF 553(B) to 353(B) HC-RF 5103(B) to 502(B) HC-UF 572(B) to 502(B) HA-LH 11K 2 to 22K 2 HA-LF 30K 24 to 55K 24 HA-LF 30K 2 · 37K 2 HA-LF S601 to 37K 1 HA-LF S701M to 37K 1M HA-LF S502 to 37K 2 HC-LF S52(B) to 302(B)	MS3102A20-29P	MS3106A20-29S(D190)	Straight	CE 02-20BS-S	6.8 to 10	CE 3057-12A-3(D265)
			Angle	CE-20BA-S		

#### 3) For connection of brake

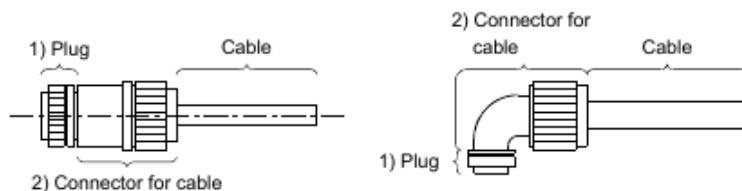

Servo Motor	Connector Supplied for Servo Motor	Cable Side Connector				
		1) Plug (DDK)	2) Connector for Cable			
			Type	Maker	Cable OD	Model
HC-SF 121(B) to 301(B) HC-SF 202(B) to 502(B) HC-SF 203(B) · 353(B) HC-UF 202(B) to 502(B) HC-SF 5121(B) to 301(B) HC-SF S202(B) to 502(B) HC-SF S203(B) · 353(B) HC-UF S202(B) to 502(B) HC-LF S202(B) · 302(B)	MS3102A10SL-4P	MS3106A10SL-4S(D190)	Straight	Nippon flex	4 to 8	ACS-08RL-MS10F
				Daiwa Dengyo	5 to 8.3	YSO-10-5 to 8
			Angle	Nippon flex	4 to 8	ACA-08RL-MS10F
				Daiwa Dengyo	5 to 8.3	YLO-10-5 to 8

### 3. CONNECTORS USED FOR SERVO MOTOR

(b) When using flexible conduits

1) For connection of power supply

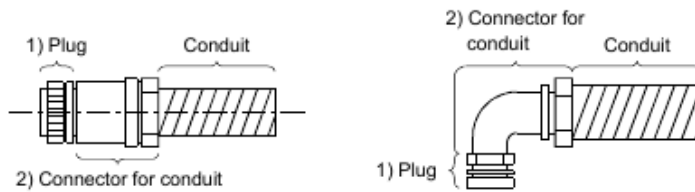

Servo Motor	Connector Supplied for Servo Motor	Cable Side Connector											
		1) Plug (DDK)	2) Connector for conduit				Conduit						
			Type	Maker	Size	Model	Model	ID					
HC-SF81(B) HC-SF52(B) to 152(B) HC-SF53(B) to 153(B) HC-RF103(B) to 203(B) HC-UF72(B) · 152(B) HC-SFS81(B) HC-SFS52(B) to 152(B) HC-SFS53(B) to 153(B) HC-RFS103(B) to 203(B) HC-UFS72(B) · 152(B) HC-LFS52(B) to 152(B)	CE05-2A22-23PD-B	CE05-6A22-23SD-B	Straight	Nippon flex	1/2	RCC-104RL-MS22F	VF-04	14.0					
					3/4	RCC-106RL-MS22F	VF-06	19.0					
					1	RCC-108RL-MS22F	VF-08	24.4					
				Daiwa Dengyo	16	MSA-16-22	FCV16	15.8					
					22	MSA-22-22	FCV22	20.8					
					28	MSA-28-22	FCV28	26.4					
			Angle	Nippon flex	1/2	RCC-304RL-MS22F	VF-04	14.0					
					3/4	RCC-306RL-MS22F	VF-06	19.0					
					1	RCC-308RL-MS22F	VF-08	24.4					
				Daiwa Dengyo	16	MAA-16-22	FCV16	15.8					
					22	MAA-22-22	FCV22	20.8					
					28	MAA-28-22	FCV28	26.4					
					HC-SF121(B) to 301(B) HC-SF202(B) to 502(B) HC-SF203(B) · 353(B) HC-RF353(B) to 503(B) HC-UF202(B) to 502(B) HC-SFS121(B) to 301(B) HC-SFS202(B) to 502(B) HC-SFS203(B) · 353(B) HC-RFS353(B) · 503(B) HC-UFS202(B) to 502(B) HA-LFS502 HC-LFS202(B) · 302(B)	CE05-2A24-10PD-B	CE05-6A24-10SD-B	Straight	Nippon flex	1/2	RCC-104RL-MS24F	VF-04	14.0
										3/4	RCC-106RL-MS24F	VF-06	19.0
1	RCC-108RL-MS24F	VF-08	24.4										
Daiwa Dengyo	16	MSA-16-24	FCV16	15.8									
	22	MSA-22-24	FCV22	20.8									
	28	MSA-28-24	FCV28	26.4									
Angle	Nippon flex	1/2	RCC-304RL-MS24F	VF-04				14.0					
		3/4	RCC-306RL-MS24F	VF-06				19.0					
		1	RCC-308RL-MS24F	VF-08				24.4					
	Daiwa Dengyo	16	MAA-16-24	FCV16				15.8					
		22	MAA-22-24	FCV22				20.8					
		28	MAA-28-24	FCV28				26.4					
		HC-SF702(B) HC-SFS702(B) HA-LFS702	CE05-2A32-17PD-B	CE05-6A32-17SD-B				Straight	Nippon flex	3/4	RCC-106RL-MS32F	VF-06	19.0
										1	RCC-108RL-MS32F	VF-08	24.4
Angle	Nippon flex				3/4	RCC-306RL-MS32F	VF-06		19.0				
					1	RCC-308RL-MS32F	VF-08	24.4					

### 3. CONNECTORS USED FOR SERVO MOTOR

#### 2) For connection of encoder

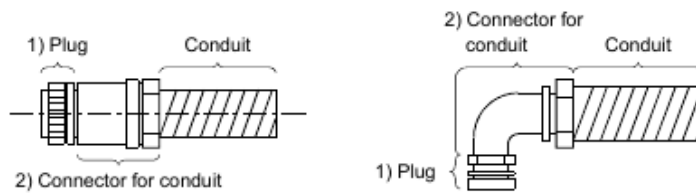

Servo Motor	Connector Supplied for Servo Motor	Cable Side Connector						
		1) Plug (DDK)	2) Connector for conduit				Conduit	
			Type	Maker	Size	Model	Model	ID
HC-SF 81(B) to 301(B) HC-SF 52(B) to 702(B) HC-SF 53(B) to 353(B) HC-RF 103(B) to 503(B) HC-UF 72(B) to 502(B) HC-SF 581(B) to 301(B) HC-SF 552(B) to 702(B) HC-SF 553(B) to 353(B) HC-RF S103(B) to 502(B) HC-UF S72(B) to 502(B) HA-LH 11K 2 to 22K 2 HA-LF 30K 24 to 55K 24 HA-LF 30K 2 · 37K 2 HA-LF S601 to 37K 1 HA-LF S701M to 37K 1M HA-LF S502 to 37K 2 HC-LF S52(B) to 302 (B)	MS3102A20-29P	MS3106A20-29S(D190)	Straight	Nippon flex	1/2	RCC-104RL-MS20F	VF-04	14.0
					3/4	RCC-106RL-MS20F	VF-06	19.0
				Daiwa Dengyo	16	MSA-16-20	FCV16	15.8
					22	MSA-22-20	FCV22	20.8
			Angle	Nippon flex	1/2	RCC-304RL-MS20F	VF-04	14.0
					3/4	RCC-306RL-MS20F	VF-06	19.0
				Daiwa Dengyo	16	MAA-16-20	FCV16	15.8
					22	MAA-22-20	FCV22	20.8

#### 3) For connection of brake

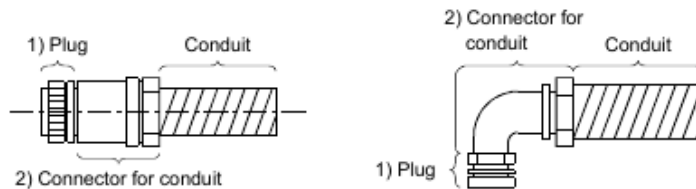

Servo Motor	Connector Supplied for Servo Motor	Cable Side Connector						
		1) Plug (DDK)	2) Connector for conduit				Conduit	
			Type	Maker	Size	Model	Model	ID
HC-SF 121(B) to 301(B) HC-SF 202(B) to 502(B) HC-SF 203(B) · 353(B) HC-UF 202(B) to 502(B) HC-SF S121(B) to 301(B) HC-SF S202(B) to 502(B) HC-SF S203(B) · 353(B) HC-UF S202(B) to 502(B) HC-LF S202(B) · 302(B)	MS3102A10S L-4P	MS3106A10SL-4S(D190)	Straight	Nippon flex	1/4	RCC-102RL-MS10F	VF-02	8.3
					Daiwa Dengyo	10	MSA-10-10	FCV10
			Angle	Nippon flex		1/4	RCC-302RL-MS10F	VF-02
					Daiwa Dengyo	10	MAA-10-10	FCV10

### 3. CONNECTORS USED FOR SERVO MOTOR

#### 3.1.4 HC-AQ series

Servo Motor	Servo Motor Side Connector (molex)	Cable Side Connector (molex)	
		Plug	Terminal
HC-AQ□(B)	(Note) 5557-12R-210	5559-12P-210	5558

Note: Terminal: 5556

#### 3.1.5 HC-KFS · HC-MFS · HC-UFS3000r/min series

Use the connectors indicated in this section or equivalent for connection of the power supply, electromagnetic brake and encoder. These connectors may be used for the EN Standard and UL/C-UL Standard but are not waterproof.

(1) For connection of power supply and brake

Servo Motor	Connector Supplied for Servo Motor (molex)	Cable Side Connector		Manual crimping tool
		Plug (molex)	Terminal (molex)	
HC-KFS□ HC-MFS□ HC-UFS13 to 73	5557-04R-210	5559-04P-210	5558PBT3L	57022-5300

Servo Motor	Connector Supplied for Servo Motor (molex)	Cable Side Connector		Manual crimping tool
		Plug (molex)	Terminal (molex)	
HC-KFS□B HC-MFS□B HC-UFS13 to 73B	5557-06R-210	5559-06P-210	5558PBT3L	57022-5300

(2) For connection of encoder

Servo Motor	Connector Supplied for Servo Motor (AMP)	Cable Side Connector		
		Housing (AMP)	Connector pin (AMP)	Cable clamp (Toa Electric Industry)
HC-KFS□(B) HC-MFS□(B) HC-UFS13 to 73(B)	1-172169-9	1-172161-9	170359-1 170363-1 (loose piece)	MT1-0002

### 3. CONNECTORS USED FOR SERVO MOTOR

#### 3.1.6 HC-UF3000r/min series (Compliance with IP65)

Use the connectors indicated in this section or equivalent for connection of the power supply, electromagnetic brake and encoder. These connectors are waterproof.

##### (1) For connection of power

Servo Motor	Connector Supplied for Servo Motor (Hirose Electric)	Cable Side Connector	
		Plug (Hirose Electric)	Cable clamp (Hirose Electric)
HC-UF□-S1	RM15WTP-4P	RM15WTJ A-4S	(Note) RM15WTP-CP(8)

Note: The numeral within the parentheses indicates the applicable cable diameter. It depends on the used cable diameter.

##### (2) For connection of encoder

Servo Motor	Connector Supplied for Servo Motor (Hirose Electric)	Cable Side Connector	
		Plug (With cable clamp) (Hirose Electric)	Cable clamp (Hirose Electric)
HC-UF□-S1	RM15WTP-10P	(Note) RM15WTJ A-10S-(7)	

Note: The numeral within the parentheses indicates the applicable cable diameter. It depends on the used cable diameter.

##### (3) For connection of brake

Servo Motor	Connector Supplied for Servo Motor (Hirose Electric)	Cable Side Connector	
		Plug (Hirose Electric)	Cable clamp (Hirose Electric)
HC-UF□-S1	RM15WTP-4P	RM15WTJ A-4S	(Note) RM15WTP-CP(6)





Note: The numeral within the parentheses indicates the applicable cable diameter. It depends on the used cable diameter.

### 3. CONNECTORS USED FOR SERVO MOTOR





#### 3.2 IP65, EN Standard-compliant options

The following options are available to satisfy the IP65 ingress protection and EN Standard.

To comply with the EN Standard, the power supply connector used must be any of these options or equivalent.

Product	Model	Description		Servo Motor
IP65-compliant encoder cable (For MR-J 2 series · MR-J 2-Super Series)	MR-ENCBL□M-H	Servo amplifier side connector (3M or equivalent) Connector: 10120-3000VE Shell kit: 10320-52F0-008	Encoder side connector (DDK) Plug: MS3106A20-29S(D190) Cable damp: CE3057-12A-3(D265) Back shell: CE02-20BS-S	HC-SF series HC-RF series HC-UF2000r/min series HA-LF-UE series HA-FF-UE series HA-SFS series HA-RFS series HC-UF S2000r/min series HA-LFS series HC-LFS series
				
Encoder cable (For MR-H□N series)	MR-ENICBL□M-H	Servo amplifier side connector (Honda Tsushin Kogyo) Connector: PCR-S20FS Case: PCR-LS20LA1	Encoder side connector (DDK) Plug: MS3106A20-29S(D190) Cable damp: CE3057-12A-3(D265) Back shell: CE02-20BS-S	HC-SF series HC-RF series HC-UF2000r/min series HA-LF-UE series
				
Encoder connector set (For MR-J 2 series · MR-J 2-Super Series)	MR-ENCNS	Servo amplifier side connector (3M or equivalent) Connector: 10120-3000VE Shell kit: 10320-52F0-008	Encoder side connector (DDK) Plug: MS3106A20-29S(D190) Cable damp: CE3057-12A-3(D265) Back shell: CE02-20BS-S	HC-SF series HC-RF series HC-UF2000r/min series HC-SFS series HC-RFS series HC-UF S2000r/min series HA-LFS series HC-LFS series
				
Encoder connector set (For MR-H□N series)	MR-ENICNS	Servo amplifier side connector (Honda Tsushin Kogyo) Connector: PCR-S20FS Case: PCR-LS20LA1	Encoder side connector (DDK) Plug: MS3106A20-29S(D190) Cable damp: CE3057-12A-3(D265) Back shell: CE02-20BS-S	HC-SF series HC-RF series HC-UF2000r/min series HA-LF series
				
EN Standard-compliant power connector set	MR-PWCNF	Plug: CE05-6A14S-2SD-B (DDK) Cable connector: YSO14-9 to 11 (Daiwa Dengyo)		HA-FF□C-UE series
				

### 3. CONNECTORS USED FOR SERVO MOTOR

Product	Model	Description	Servo Motor
IP65/EN Standard-compliant power connector set	MR-PWCNS1	 Plug: CE05-6A22-23SD-B-BSS Cable damp: CE3057-12A-2 (D265) (DDK)	HC-SF 81(B) HC-SF 52(B) to 152(B) HC-SF 53(B) to 153(B) HC-RF 103(B) to 203(B) HC-UF 72(B) · 152(B) HC-SFS81(B) HC-SFS52(B) to 152(B) HC-SF S53(B) to 153(B) HC-RFS103(B) to 203(B) HC-UF S72(B) · 152(B) HC-LFS52(B) to 152(B)
IP65/EN Standard-compliant power connector set	MR-PWCNS2	 Plug: CE05-6A22-10SD-B-BSS Cable damp: CE3057-16A-2 (D265) (DDK)	HC-SF 121(B) to 301(B) HC-SF 202(B) to 502(B) HC-SF 203(B) · 353(B) HC-RF 353(B) · 503(B) HC-UF 202(B) to 502(B) HC-SFS121(B) to 301(B) HC-SFS202(B) to 502(B) HC-SF S203(B) · 353(B) HC-RFS353(B) · 503(B) HC-UF S202(B) · 352(B) HA-LFS502 HC-LFS202(B) · 302(B)
Power connector set	MR-PWCNS3	 Plug: CE05-6A32-17SD-B-BSS Cable damp: CE3057-20A-1 (D265) (DDK)	HC-SF 702(B) HC-SFS702(B) HA-LFS702
IP65/EN Standard-compliant brake connector set	MR-BKCN (Note)	 Plug: MS3106A10SL-4S(D190) (DDK) Cable connector: YSO10-5 to 8 (Daiwa Dengyo)	HA-FF□CB-UE HC-SF 121B to 301B HC-SF 202B to 502B HC-SF 203B · 353B HC-UF 202B · 502B HC-SFS121B to 301B HC-SFS202B to 502B HC-SFS203B · 353B HC-UF S202B to 502B HC-LFS202B · 302B

Note: If it is used with the HA-FF · C-UE, the servo motor does not improve in ingress protection (IP54).

### 3. CONNECTORS USED FOR SERVO MOTOR

#### 3.3 Signal arrangement of encoder connectors

The encoder connector of each servo motor has the following signal arrangement. The connectors shown are as seen from the pin side.

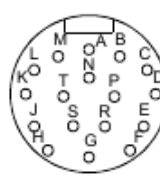
Servo Motor Series	Signal Arrangement																																						
HC-KF(-UE) series HC-MF(-UE) series HA-FF series HC-UF 3000r/min series HC-KFS series HC-MFS series HC-UFS3000r/min series	Encoder connectors 1-172169-9 (AMP) <table border="1" style="margin-left: auto; margin-right: auto;"> <tr> <td>1</td> <td>2</td> <td>3</td> </tr> <tr> <td>MR</td> <td>MRR</td> <td>BAT</td> </tr> <tr> <td>4</td> <td>5</td> <td>6</td> </tr> <tr> <td>MD</td> <td>MDR</td> <td></td> </tr> <tr> <td>7</td> <td>8</td> <td>9</td> </tr> <tr> <td>P5</td> <td>LG</td> <td>SHD</td> </tr> </table>	1	2	3	MR	MRR	BAT	4	5	6	MD	MDR		7	8	9	P5	LG	SHD																				
1	2	3																																					
MR	MRR	BAT																																					
4	5	6																																					
MD	MDR																																						
7	8	9																																					
P5	LG	SHD																																					
HA-FF□C-UE series HC-SF series HC-RF series HC-UF 2000r/min series HA-LH series HA-LF series HC-SFS series HC-RFS series HC-UFS2000r/min series HA-LFS series HC-LFS series	Encoder connectors <table border="1" style="display: inline-table; margin-right: 20px;"> <tr> <th>Pin</th> <th>Signal</th> </tr> <tr><td>A</td><td>MD</td></tr> <tr><td>B</td><td>MDR</td></tr> <tr><td>C</td><td>MR</td></tr> <tr><td>D</td><td>MRR</td></tr> <tr><td>E</td><td></td></tr> <tr><td>F</td><td>BAT</td></tr> <tr><td>G</td><td>LG</td></tr> <tr><td>H</td><td></td></tr> <tr><td>J</td><td></td></tr> </table>  <table border="1" style="display: inline-table;"> <tr> <th>Pin</th> <th>Signal</th> </tr> <tr><td>K</td><td></td></tr> <tr><td>L</td><td></td></tr> <tr><td>M</td><td></td></tr> <tr><td>N</td><td>SHD</td></tr> <tr><td>P</td><td></td></tr> <tr><td>R</td><td>LG</td></tr> <tr><td>S</td><td>P5</td></tr> <tr><td>T</td><td></td></tr> </table>	Pin	Signal	A	MD	B	MDR	C	MR	D	MRR	E		F	BAT	G	LG	H		J		Pin	Signal	K		L		M		N	SHD	P		R	LG	S	P5	T	
Pin	Signal																																						
A	MD																																						
B	MDR																																						
C	MR																																						
D	MRR																																						
E																																							
F	BAT																																						
G	LG																																						
H																																							
J																																							
Pin	Signal																																						
K																																							
L																																							
M																																							
N	SHD																																						
P																																							
R	LG																																						
S	P5																																						
T																																							
HC-AQ series	Motor connector <table border="1" style="margin-left: auto; margin-right: auto;"> <tr> <td>12</td> <td>6</td> </tr> <tr> <td>MRR</td> <td>MR</td> </tr> <tr> <td>11</td> <td>5</td> </tr> <tr> <td>LG</td> <td>P5</td> </tr> <tr> <td>10</td> <td>4</td> </tr> <tr> <td></td> <td>SHD</td> </tr> <tr> <td>9</td> <td>3</td> </tr> <tr> <td>B1</td> <td>B2</td> </tr> <tr> <td>8</td> <td>2</td> </tr> <tr> <td>W</td> <td>U</td> </tr> <tr> <td>7</td> <td>1</td> </tr> <tr> <td>V</td> <td>E</td> </tr> </table>	12	6	MRR	MR	11	5	LG	P5	10	4		SHD	9	3	B1	B2	8	2	W	U	7	1	V	E														
12	6																																						
MRR	MR																																						
11	5																																						
LG	P5																																						
10	4																																						
	SHD																																						
9	3																																						
B1	B2																																						
8	2																																						
W	U																																						
7	1																																						
V	E																																						





## 4. INSPECTION

### 4. INSPECTION

 <b>WARNING</b>	<ul style="list-style-type: none"> <li>· Before starting maintenance and/or inspection, make sure that the charge lamp is off more than 10 minutes after power-off. Then, confirm that the voltage is safe in the tester or the like. Otherwise, you may get an electric shock.</li> <li>· Any person who is involved in inspection should be fully competent to do the work. Otherwise, you may get an electric shock. For repair and parts replacement, contact your sales representative.</li> </ul>
--	---

<b>POINT</b>	Do not disassemble and/or repair the equipment on customer side.
--------------	--

#### (1) Inspection

It is recommended to make the following checks periodically:

- (a) Check the servo motor bearings, brake section, etc. for unusual noise.
- (b) Check the cables and the like for scratches and cracks. Especially when the junction cable is movable, perform periodic inspection according to operating conditions.
- (c) Check the servo motor shaft and coupling for misalignment.
- (d) Check the power supply connector and encoder connector tightening screws for looseness.

#### (2) Life

The following parts must be changed periodically as listed below. If any part is found faulty, it must be changed immediately even when it has not yet reached the end of its life, which depends on the operating method and environmental conditions. For parts replacement, please contact your sales representative.

Part Name	Guideline of Life	Remarks
Bearings	20,000 to 30,000 hours	The Guideline of Life field gives the reference time. If any fault is found before this time is reached, the part must be changed.
Encoder	20,000 to 30,000 hours	
Oil seal	5,000 hours	
Cooling fan	20,000 hours	

#### (a) Bearings

When the servo motor is run at rated speed under rated load, change the bearings in 20,000 to 30,000 hours as a guideline. This differs on the operating conditions. The bearings must also be changed if unusual noise or vibration is found during inspection.

#### (b) Oil seal

Must be changed in 5,000 hours of operation at rated speed as a guideline. These parts must also be changed if oil leakage, etc. is found during inspection.



## 5. SPECIFICATIONS

### 5. SPECIFICATIONS

#### 5.1 Standard specifications

Servo Motor		HC-MF Series (ultra low inertia, small capacity)					HA-FF Series (low inertia, small capacity)						
		053	13	23	43	73	053	13	23	33	43	63	
Applicable servo amplifier	MR-H□AN/BN/ACN/TN	20	20	40	60	100	10	10	20	40	40	60	
	MR-J 2□A/B/C	10	10	20	40	70	10	10	20	40	40	60	
Continuous characteristics (Note 1 · 11)	Rated output [kW]	0.05	0.1	0.2	0.4	0.75	0.05	0.1	0.2	0.3	0.4	0.6	
	Rated torque	[N · m]	0.16	0.32	0.64	1.3	2.4	0.16	0.32	0.64	0.95	1.3	1.9
		[oz · in]	22.7	45.3	90.7	184	340	22.7	45.3	90.7	135	184	269
Rated speed (Note 1)		[r/min]	3000					3000					
Maximum speed		[r/min]	4500					4000					
Instantaneous permissible speed		[r/min]	5175					4600					
Maximum torque	[N · m]	0.48	0.95	1.9	3.8	7.2	0.48	0.95	1.9	2.9	3.8	5.7	
	[oz · in]	68.0	135	269	538	1020	68.0	135	269	411	538	808	
Power rate at continuous rated torque		[kW/s]	13.47	34.13	46.02	116.55	94.43	4.0	10.2	11.7	18.1	17.2	30.1
Inertia moment (Note 3)	J [ $\times 10^{-4}$ kg · m <sup>2</sup> ]	0.019	0.03	0.088	0.143	0.6	0.063	0.10	0.35	0.50	0.98	1.2	
	WK <sup>2</sup> [oz · in <sup>2</sup> ]	0.104	0.16	0.48	0.78	3.28	0.344	0.55	1.91	2.73	5.36	6.56	
Recommended ratio of load inertia moment to servo motor shaft inertia moment (Note 2)			30 times or less					10 times or less					
Regenerative brake duty (times/min) (Note 4)	MR-H series	Servo amplifier' built-in regenerative brake resistor	(Note 5)	(Note 5)	(Note 5)	4275	1726	(Note 5)	(Note 5)	(Note 5)	1500	750	600
		MR-RB013(10W)	(Note 5)	(Note 5)				2071	1363	370			
		MR-RB033(30W)	(Note 5)	(Note 5)				(Note 5)	4088	1109			
	MR-J 2 series	MR-RB32(300W)			(Note 5)	(Note 5)	(Note 5)				(Note 5)	3983	3046
		Servo amplifier' built-in regenerative brake resistor	(Note 5)	(Note 5)	(Note 5)	1010	400	(Note 5)	(Note 5)	(Note 5)	320	150	120
		MR-RB032(30W)				3000	600				950	450	360
	MR-RB12(100W)				(Note 5)	2400				3200	1500	1200	
Power supply capacity		Refer to "Power supply equipment capacity and generated loss of servo amplifiers" in Servo Amplifier Instruction Manual.											
Rated current [A]		0.85	0.85	1.5	2.8	5.1	0.6	1.1	1.3	1.9	2.5	3.6	
Maximum current [A]		2.6	2.6	5	9	18	1.8	3.3	3.9	5.7	7.5	10.8	
Speed/position detector		Encoder (resolution : 8192 pulse/rev)					Encoder (resolution : 8192 pulse/rev)						
Accessories		Encoder					Encoder, V ring						
Insulation class		Class B					Class B						
Structure		Totally-enclosed, self-cooled (protection type: IP44 (Note 6 · 12))					Totally-enclosed, self-cooled (protection type: IP44 (Note 8 · 9 · 12))						
Environmental conditions (Note 7)		Refer to section 2.1					Refer to section 2.1						
Weight (Note 3)	[kg]	0.4	0.53	0.99	1.45	3.0	1.3	1.5	2.3	2.6	4.2	4.8	
	[lb]	0.88	1.17	2.18	3.20	6.61	2.87	3.31	5.07	5.73	9.26	10.6	

## 5. SPECIFICATIONS

Servo Motor		HC-SF 1000r/min Series (middle inertia, middle capacity)				HC-SF 2000r/min Series (middle inertia, middle capacity)							
		81	121	201	301	52	102	152	202	352	502	702	
Applicable servo amplifier	MR-H□AN/BN/ACN/TN	100	200	200	350	60	100	200	200	350	500	700	
	MR-J 2□A/B/C	100	200	200	350	60	100	200	200	350			
Continuous characteristics (Note 1 · 11)	Rated output [kW]	0.85	1.2	2.0	3.0	0.5	1.0	1.5	2.0	3.5	5.0	7.0	
	Rated torque	[N · m]	8.12	11.5	19.1	28.6	2.39	4.78	7.16	9.55	16.7	23.9	33.4
		[oz · in]	1151	1630	2707	4053	339	677	1015	1353	2367	3387	4733
Rated speed (Note 1)	[r/min]	1000				2000							
Maximum speed	[r/min]	1500	1200			3000			2500		2000		
Instantaneous permissible speed	[r/min]	1725	1380			345			2850		2300		
Maximum torque	[N · m]	24.4	34.4	57.3	85.9	7.16	14.4	21.6	28.5	50.1	71.6	100.0	
	[oz · in]	3458	4875	8120	12173	1015	2041	3061	4039	7100	10146	14171	
Power rate at continuous rated torque	[kW/s]	32.9	30.9	44.5	81.3	8.7	16.7	25.6	21.5	34.1	56.5	69.7	
Inertia moment (Note 3)	J [ $\times 10^{-4}$ kg · m <sup>2</sup> ]	20.0	42.5	82	101	6.6	13.7	20.0	4.5	82.0	101	160	
	WK <sup>2</sup> [oz · in <sup>2</sup> ]	109	232	448	552	36.1	74.9	109	232	448	552	875	
Recommended ratio of load inertia moment to servo motor shaft inertia moment (Note 2)		15 times or less				15 times or less							
Regenerative brake duty [times/min] (Note 4)	MR-H series	Servo amplifier built-in regenerative brake resistor	440	335	174	141	207	170	179	84	43	39	32
		MR-RB31(300W)											57
		MR-RB32(300W)	1649				1241	638					
		MR-RB30(300W)				326					100	90	
		MR-RB34(300W)		774	401				412	193			
		MR-RB50(500W)				543					167	150	
		MR-RB51(500W)											95
	MR-J 2 series	Servo amplifier built-in regenerative brake resistor	140	240	100	84	56	54	136	64	31		
		MR-RB032(30W)	220				165	80					
		MR-RB12(100W)	740				560	270					
		MR-RB32(300W)	2220					810					
		MR-RB30(300W)		730	330	250			408	192	95		
		MR-RB50(500W)		1216	550	430			680	320	158		
		Power supply capacity	Refer to "Power supply equipment capacity and generated loss of servo amplifiers" in Servo Amplifier Instruction Manual.										
Rated current [A]	5.1 7.1 9.6 16 3.2 6 9 11 17 28 35												
Maximum current [A]	15.3 21.3 28.8 48 9.6 18 27 33 51 84 105												
Speed/position detector	Encoder (resolution: 16384 pulse/rev)				Encoder (resolution: 16384 pulse/rev)								
Accessories	Encoder · Oil seal				Encoder · Oil seal								
Insulation class	Class F				Class F								
Structure	Totally-enclosed, self-cooled (protection type: IP65)				Totally-enclosed, self-cooled (protection type: IP65(Note 12))								
Environmental conditions (Note 7)	Refer to section 2.1				Refer to section 2.1								
Weight (Note 3)	[kg]	9.0	12	19	23	5.0	7.0	9.0	12.0	19.0	23	32	
	[lb]	19.8	26.5	41.9	50.7	11.0	15.4	19.8	26.5	41.9	50.7	70.5	

## 5. SPECIFICATIONS

Servo Motor		HC-SF 3000r/min Series (middle inertia, middle capacity)					HC-RF Series (ultra low inertia, middle capacity)					
		53	103	153	203 (Note 13)	353 (Note 13)	103	153	203	353	503	
Applicable servo amplifier	MR-H□AN/BN/ACN/TN	60	100	200	200	350	200	200	350	500	500	
	MR-J 2-□A/B/C	60	100	200	200	350	200	200	350			
Continuous characteristics (Note 1 · 11)	Rated output [kW]	0.5	1.0	1.5	2.0	3.5	1.0	1.5	2.0	3.5	5.0	
	Rated torque	[N · m] [oz · in]	1.59 225	3.18 451	4.78 677	6.37 903	11.1 1573	3.18 451	4.78 677	6.37 903	11.1 1573	15.9 2253
Rated speed (Note 1)		[r/min]	3000					3000				
Maximum speed		[r/min]	3000					4500				
Instantaneous permissible speed		[r/min]	3450					5175				
Maximum torque	[N · m]	4.77	9.55	14.3	19.1	33.4	7.95	11.9	15.9	27.9	39.7	
	[oz · in]	676	1353	2026	2707	4733	1127	1686	2253	3954	5626	
Power rate at continuous rated torque		[kW/s]	3.8	7.4	11.4	9.5	15.1	67.4	120	176	150	211
Inertia moment (Note 3)	J [ $\times 10^{-4}$ kg · m <sup>2</sup> ]	6.6	13.7	20.0	42.5	82.0	1.5	1.9	2.3	8.6	12.0	
	WK <sup>2</sup> [oz · in <sup>2</sup> ]	36.1	74.9	109.3	232.4	448.3	8.2	10.4	12.6	47.0	65.6	
Recommended ratio of load inertia moment to servo motor shaft inertia moment (Note 2)		15 times or less					5 times or less					
Regenerative brake duty (times/min) (Note 4)	MR-H series	Servo amplifier built-in regenerative brake resistor	92	71	79	37	19	1056	834	689	174	125
		MR-RB 32(300W)	552	267								
		MR-RB 30(300W)					45			1589	401	288
		MR-RB 34(300W)			183	86		2437	1924			
		MR-RB 50(500W)					74			2648	669	479
	MR-J 2 series	Servo amplifier built-in regenerative brake resistor	25	24	82	24	14	1090	860	710		
		MR-RB032(30W)	73	36								
		MR-RB12(100W)	250	120								
		MR-RB32(300W)		360								
		MR-RB30(300W)			250	70	42	3270	2580	2130		
MR-RB50(500W)			410	110	70	5450	4300	3550				
Power supply capacity		Refer to "Power supply equipment capacity and generated loss of servo amplifiers" in Servo Amplifier Instruction Manual.										
Rated current [A]		3.2	5.3	8.6	10.4	16.4	6.1	8.8	14	23	28	
Maximum current [A]		9.6	15.9	25.8	31.2	49.2	18.4	23.4	37	58	70	
Speed/position detector		Encoder (resolution : 16384 pulse/rev)					Encoder (resolution : 16384 pulse/rev)					
Accessories		Encoder · Oil seal					Encoder · Oil seal					
Insulation class		Class F					Class F					
Structure		Totally-enclosed, self-cooled (protection type: IP65)					Totally-enclosed, self-cooled (protection type: IP65)(Note 12))					
Environmental conditions (Note 7)		Refer to section 2.1					Refer to section 2.1					
Weight (Note 3)	[kg]	5.0	7.0	9.0	12	19	3.9	5.0	6.2	12.0	17.0	
	[lb]	11.0	15.4	19.8	26.5	41.9	8.6	11.0	13.7	26.5	37.5	

## 5. SPECIFICATIONS

Servo Motor			HC-UF 2000r/min Series (pancake type · middle capacity)					HC-UF 3000r/min Series (pancake type · small capacity)				HA-LH Series (low inertia · large capacity)			
			72	152	202	352	502	13	23	43	73 (Note 13)	11K	15K	22K	
Item	Applicable servo amplifier		MR-H <sup>+</sup> AN/BN/ACN/TN	100	200	350	500	500	10	40	60	100	11K	15K	22K
			MR-J 2 <sup>+</sup> A/B/C	70	200	350			10	20	40	70			
Continuous characteristics (Note 1 · 11)	Rated output [kW]			0.75	1.5	2.0	3.5	5.0	0.1	0.2	0.4	0.75	11	15	22
	Rated torque	[N · m]		3.58	7.16	9.55	16.7	23.9	0.32	0.64	1.3	2.4	52.5	71.6	105
		[oz · in]		507	1015	1353	2367	3387	45	91	184	340	7435	10139	14869
Rated speed (Note 1)		[r/min]	2000					3000				2000			
Maximum speed		[r/min]	3000			2500		4500				2000			
Instantaneous permissible speed		[r/min]	3450			2875		5175				2300			
Maximum torque	[N · m]		10.7	21.6	28.5	50.1	71.6	0.95	1.9	3.8	7.2	158	215	263	
	[oz · in]		1516	3061	4039	7100	10146	135	269	538	1020	22375	30447	37244	
Power rate at continuous rated torque		[kW/s]	12.3	23.2	23.9	36.5	49.6	15.5	19.2	47.7	9.66	235	177	278	
Inertia moment (Note 3)	J	[×10 <sup>-4</sup> kg · m <sup>2</sup> ]	10.4	22.1	38.2	76.5	115	0.066	0.241	0.365	5.90	118	290	395	
	WK <sup>2</sup>	[oz · in <sup>2</sup> ]	56.9	120.8	208.9	418.3	628.8	0.4	1.3	2.0	32.3	642.4	1585.6	2159.6	
Recommended ratio of load inertia moment to servo motor shaft inertia moment (Note 2)			15 times or less									10 times or less			
Regenerative brake duty (times/min) (Note 4)	MR-H Series	Servo amplifier built-in regenerative brake resistor	211	161	93	44	31	(Note 5)	2530	1669	165	85 (Note 10)	70 (Note 10)	55 (Note 10)	
		MR-RB013(10W)							2241 (Note 5)						
		MR-RB033(30W)													
		MR-RB32(300W)	791							(Note 5)	(Note 5)	619			
		MR-RB30(300W)			215	102	72								
		MR-RB34(300W)			372										
		MR-RB50(500W)			358	169	119								
		MR-RB54(500W)			620										
		MR-RB65(800W)											500 (Note 10)		
	MR-RB66(1300W)												850 (Note 10)		
	MR-RB67(1300W)													850 (Note 10)	
	MR-J 2 series	Servo amplifier built-in regenerative brake resistor	53	124	68			(Note 5)	(Note 5)	410	41				
		MR-RB032(30W)	79							1230	62				
		MR-RB12(100W)	87							4106	206				
		MR-RB30(300W)			372	203									
MR-RB50(300W)				620	338										
Power supply capacity			Refer to "Power supply equipment capacity and generated loss of servo amplifiers" in Servo Amplifier Instruction Manual.												
Rated current		[A]	5.4	9.7	14	23	28	0.76	1.5	2.8	4.3	68	87	126	
Maximum current		[A]	16.2	29.1	42	69	84	2.5	4.95	9.24	12.9	204	261	315	
Speed/position detector			Encoder (resolution : 16384 pulse/rev)					Encoder (resolution : 8192 pulse/rev)				Encoder (resolution : 16384 pulse/rev)			
Cooling fan	Power supply	Voltage, frequency										200/220V 50/60Hz			
	Power consumption [W]											42/54W			
	Rated current [A]											0.21/0.25A			
	Speed [r/min]											3000/3600r/min			
Accessories			Encoder · Oil seal					Encoder · Oil seal				Encoder · Oil seal			
Insulation class			Class F					Class B				Class F			
Structure			Totally-enclosed, self-cooled (protection type: IP65(Note9))					Totally-enclosed, self-cooled (protection type: IP65(Note9))				Totally-enclosed, force-cooling (protection type: J P44)			
Environmental conditions (Note 7)			Refer to section 2.1									Refer to section 2.1			
Weight (Note 3)			[kg]	8.0	11.0	16.0	20.0	24.0	0.8	1.5	1.7	5.0	70	108	135
			[lb]	17.6	24.3	35.3	44.1	52.9	1.8	3.3	3.7	11.0	154.3	238.1	297.6

## 5. SPECIFICATIONS

Item		Servo Motor	HC-KF Series (low inertia · small capacity)			
			053	13	23	43
Applicable servo amplifier		MR-H□AN/ BN/ACN/TN	10	10	20	40
		MR-J 2-□	10A-A16	10A-A15	20A-A15	40A-A15
			10B-A16	10B-A15	20B-A15	40B-A15
		10C-A16	10C-A15	20C-A15	40C-A15	
Continuous characteristics (Note 1 · 11)	Rated output	[kW]	0.05	0.1	0.2	0.4
	Rated torque	[N · m]	0.16	0.32	0.64	1.3
		[oz · in]	22.7	45.3	90.7	184
Rated speed (Note 1)		[r/min]	3000			
Maximum speed		[r/min]	4500			
Instantaneous permissible speed		[r/min]	5175			
Maximum torque		[N · m]	0.48	0.95	1.9	3.8
		[oz · in]	68.0	135	269	538
Power rate at continuous rated torque		[kW/s]	4.78	12.1	9.65	24.2
Inertia moment (Note 3)	J	[× 10 <sup>-4</sup> kg · m <sup>2</sup> ]	0.053	0.084	0.42	0.67
	WK <sup>2</sup>	[oz · in <sup>2</sup> ]	0.29	0.459	2.296	3.663
Recommended ratio of load inertia moment to servo motor shaft inertia moment (Note 2)		15 times or less				
Regenerative brake duty [times/min] (Note 4)	MR-H series	Servo amplifier's built-in regenerative brake resistor	(Note 5)	(Note 5)	(Note 5)	
		MR-RB013(10W)	(Note 5)	(Note 5)		
		MR-RB033(30W)	(Note 5)	(Note 5)		
	MR-J 2 series	Servo amplifier's built-in regenerative brake resistor	(Note 5)	(Note 5)	(Note 5)	220
		MR-RB032(30W)			(Note 5)	660
		MR-RB12(100W)			(Note 5)	2200
Power supply capacity		Refer to "Power supply equipment capacity and generated loss of servo amplifiers" in Servo Amplifier Instruction Manual.				
Rated current		[A]	0.83	0.71	1.1	2.3
Maximum current		[A]	2.5	2.2	3.4	6.9
Speed/position detector		Encoder (resolution: 8192 pulses/rev)				
Accessory		Encoder				
Insulation class		Class B				
Structure		Totally-enclosed, self-cooled (protection type: IP44 (Note 6))				
Environmental conditions (Note 7)		Refer to Section 2.1.				
Weight		[kg]	0.40	0.53	0.99	1.45
		[lb]	0.882	1.168	2.18	3.20



## 5. SPECIFICATIONS

Item		Servo Motor			
		HC-AQ Series (24VDC-compatible · ultra low inertia · small capacity)			
		0135	0235	0335	
Applicable servo amplifier		MR-J 2-03A5 MR-J 2-03B5 MR-J 2-03C5			
Continuous characteristics (Note 1 · 11)	Rated output [kW]	0.01	0.02	0.03	
	Rated torque	[N · m]	0.0318	0.0637	0.0955
		[oz · in]	4.503	9.021	13.524
Rated speed (Note 1) [r/min]		3000			
Maximum speed [r/min]		5000		4500	
Instantaneous permissible speed [r/min]		5750		5175	
Maximum torque	[N · m]	0.0955	0.191	0.287	
	[oz · in]	13.524	27.048	40.643	
Power rate at continuous rated torque [kW/s]		2.0	5.6	9.7	
Inertia moment (Note 3)	J [ $\times 10^{-4}$ kg · m <sup>2</sup> ]	0.0050	0.0072	0.0094	
	WK <sup>2</sup> [oz · in <sup>2</sup> ]	0.027	0.039	0.051	
Recommended ratio of load inertia moment to servo motor shaft inertia moment (Note 2)		30 times or less			
Power supply capacity		Refer to "Power supply equipment capacity and generated loss of servo amplifiers" in Servo Amplifier Instruction Manual.			
Rated current [A]		2.4	2.4	2.3	
Maximum current [A]		7.7	7.7	7.4	
Speed/position detector		Encoder (resolution: 8192 pulses/rev)			
Accessory		Encoder			
Insulation class		Class B			
Structure		Totally-enclosed, self-cooled (protection type: IP55 (Note 6))			
Environmental conditions (Note 7)		Refer to Section 2.1.			
Weight (Note 3)	[kg]	0.19	0.22	0.25	
	[lb]	0.419	0.485	0.551	

## 5. SPECIFICATIONS

Servo Motor		HA-LF Series (three-phase, 200VAC-compatible, low inertia - large capacity)		
Item		30K2	37K2	
Applicable servo amplifier	MR-H□AN/BN	30K	37K	
Compatible converter unit		MR-HP 30KA		
Continuous characteristics (Note 1 - 11)	Rated output [kW]	30	37	
	Rated torque	[N · m]	143	177
		[oz · in]	20250.6	25065.4
Rated speed (Note 1) [r/min]		2000		
Maximum speed [r/min]		2000		
Instantaneous permissible speed [r/min]		2300		
Maximum torque	[N · m]	358	442	
	[oz · in]	50697.2	62592.6	
Power rate at continuous rated torque [kW/s]		373	480	
Inertia moment	J [ $\times 10^{-4}$ kg · m <sup>2</sup> ]	550	650	
	WK <sup>2</sup> [oz · in <sup>2</sup> ]	3007.1	3553.8	
Recommended ratio of load inertia moment to servo motor shaft inertia moment		10 times or less		
Regenerative brake duty [times/min] (Note 4)	MR-RB139 (1300W)	58	49	
	MR-RB137 (3900W)	174	147	
Power supply capacity		Refer to "Power supply equipment capacity and generated loss of servo amplifiers" in Servo Amplifier Instruction Manual.		
Rated current [A]		166	102	
Maximum current [A]		415	255	
Speed/position detector		Encoder (resolution: 16384 pulse/rev)		
Cooling fan	Power supply	Voltage · frequency Three-phase 200 to 230VAC 50/60Hz		
	Power consumption [W]	45(50Hz)/63(60Hz)		
	Rated current [A]	0.32(50Hz)/0.35(60Hz)	0.32(50Hz)/63(60Hz)	
	Speed [r/min]	2650(50Hz)/3100(60Hz)		
Accessories		Encoder · oil seal		
Insulation class		Class F		
Structure		Totally-enclosed force-cooled (protection type: IP44)		
Environmental conditions (Note 7)		Refer to Section 2.1		
Weight (Note 3)	[kg]	160	180	
	[lb]	352.7	396.8	

## 5. SPECIFICATIONS

Item		Servo Motor	HA-LF Series (three-phase, 400VAC-compatible, low Inertia, large Capacity)			
			30K24	37K24	45K24	55K24
Applicable servo amplifier	MR-H□AN4/BN4	30K	37K	45K	55K	
Compatible converter unit		MR-HP55KA4				
Continuous characteristics (Note 1 . 11)	Rated output	[kW]	30	37	45	55
	Rated torque	[N · m]	143	177	215	263
		[oz · in]	20250.6	25065.4	30446.6	37244.0
Rated speed (Note 1)		[r/min]	2000			
Maximum speed		[r/min]	2000			
Instantaneous permissible speed		[r/min]	2300			
Maximum torque		[N · m]	358	442	537	657
		[oz · in]	50697.2	62592.6	76045.8	930392
Power rate at continuous rated torque		[kW/s]	373	480	427	526
Inertia moment (Note 3)	J	[×10 <sup>-4</sup> kg · m <sup>2</sup> ]	550	650	1080	1310
	WK <sup>2</sup>	[oz · in <sup>2</sup> ]	3007.095	3553.84	5904.84	7162.354
Recommended ratio of load inertia moment to servo motor shaft inertia moment (Note 2)			10 times or less			
Regenerative brake duty [times/min] (Note 4)	MR-RB136-4 (1300W)		58	49	30	24
	Three MR-B138-4's (3900W)		174	147	89	73
Power supply capacity			Refer to "Power supply equipment capacity and generated loss of servo amplifiers" in Servo Amplifier Instruction Manual.			
Rated current		[A]	83	102	131	143
Maximum current		[A]	208	255	328	358
Speed/position detector			Encoder (resolution: 16384 pulses/rev)			
Cooling fan	Power supply	Voltage · frequency	Three-phase 380 to 460VAC 50/60Hz			
		Power consumption [W]	63(50Hz)/83(60Hz)		110(50Hz)/150(60Hz)	
	Rated current	[A]	0.09(50Hz)/0.11(60Hz)		0.20(50Hz)/0.22(60Hz)	
	Speed	[r/min]	2720(50Hz)/2980(60Hz)		2650(50Hz)/3000(60Hz)	
Accessories			Encoder, oil seal			
Insulation class			Class F			
Structure			Totally-enclosed, force-cooled (protection type: IP44)			
Environmental conditions (Note 7)			Refer to Section 2.1.			
Weight (Note 3)		[kg]	160	180	230	250
		[lb]	352.739	396.832	507.063	551.155

## 5. SPECIFICATIONS

Servo Motor		HC-MFS Series (ultra low inertia • small capacity)					HC-KFS Series (low inertia • small capacity)					
		053	13	23	43	73	053	13	23	43	73	
Applicable servo amplifier/drive unit	MR-J 2S-□A/B/CP	10	10	20	40	70	10	10	20	40	70	
	MR-J 2M-□DU	10	10	20	40	70	10	10	20	40	70	
Continuous characteristics (Note 1 • 11)	Rated output [kW]	0.05	0.1	0.2	0.4	0.75	0.05	0.1	0.2	0.4	0.75	
	Rated torque	[N • m]	0.16	0.32	0.64	1.3	2.4	0.16	0.32	0.64	1.3	2.4
	[oz • in]	22.7	45.3	90.7	184	340	22.7	45.3	90.7	184	340	
Rated speed (Note 1)	[r/min]	3000					3000					
Maximum speed	[r/min]	4500					4500					
Instantaneous permissible speed	[r/min]	5175					5175					
Maximum torque	[N • m]	0.48	0.95	1.9	3.8	7.2	0.48	0.95	1.9	3.8	7.2	
	[oz • in]	68.0	135	269	538	1020	68.0	135	269	538	1020	
Power rate at continuous rated torque	[kW/s]	13.47	34.13	46.02	116.55	94.43	4.78	12.1	9.65	24.2	37.7	
Inertia moment (Note 3)	J [ $\times 10^{-4}$ kg • m <sup>2</sup> ]	0.019	0.03	0.088	0.143	0.6	0.053	0.084	0.42	0.67	1.51	
	WK <sup>2</sup> [oz • in <sup>2</sup> ]	0.104	0.16	0.48	0.78	3.28	0.29	0.459	2.296	3.663	8.26	
Recommended ratio of load inertia moment to servo motor shaft inertia moment (Note 2)		30 times or less					10 times or less					
Regenerative brake duty [times/min] (Note 4)	MR-J 2S series	Servo amplifier* built-in regenerative brake resistor	(Note 5)	(Note 5)	(Note 5)	1010	400	(Note 5)	(Note 5)	(Note 5)	220	190
		MR-RB032(30W)				3000	600	(Note 5)	(Note 5)	(Note 5)	660	280
		MR-RB12(100W)				(Note 5)	2400	(Note 5)	(Note 5)	(Note 5)	2200	940
		MR-RB32(300W)					(Note 5)					2800
Power supply capacity		Refer to "Power supply equipment capacity and generated loss of servo amplifiers" in Servo Amplifier Instruction Manual.										
Rated current	[A]	0.85	0.85	1.5	2.8	5.1	0.83	0.71	1.1	2.3	5.8	
Maximum current	[A]	2.6	2.6	5	9	18	2.5	2.2	3.4	6.9	18.6	
Speed/position detector		Encoder (resolution : 131072 pulse/rev)					Encoder (resolution : 131072 pulse/rev)					
Accessories		Encoder					Encoder, V ring					
Insulation class		Class B					Class B					
Structure		Totally-enclosed, self-cooled (protection type: IP55 (Note 6,7))					Totally-enclosed, self-cooled (protection type: IP44 (Note 6,12))					
Environmental conditions (Note 7)		Refer to section 2.1					Refer to section 2.1					
Weight (Note 3)	[kg]	0.4	0.53	0.99	1.45	3.0	0.40	0.53	0.99	1.45	3.0	
	[lb]	0.88	1.17	2.18	3.20	6.61	0.882	1.168	2.18	3.20	6.61	

## 5. SPECIFICATIONS

Servo Motor		HC-SFS1000r/min Series (middle inertia, middle capacity)				HC-SFS 2000r/min Series (middle inertia, middle capacity)							
		81	121	201	301	52	102	152	202	352	502	702	
Applicable servo amplifier/drive unit	MR-J 2S-□A/B/CP	100	200	200	350	60	100	200	200	350	500	700	
Continuous characteristics (Note 1・11)	Rated output [kW]	0.85	1.2	2.0	3.0	0.5	1.0	1.5	2.0	3.5	5.0	7.0	
	Rated torque	[N・m]	8.12	11.5	19.1	28.6	2.39	4.78	7.16	9.55	16.7	23.9	33.4
		[oz・in]	1151	1630	2707	4053	339	677	1015	1353	2367	3387	4733
Rated speed (Note 1)	[r/min]	1000				2000							
Maximum speed	[r/min]	1500	1200			3000			2500		2000		
Instantaneous permissible speed	[r/min]	1725	1380			345			2850		2300		
Maximum torque	[N・m]	24.4	34.4	57.3	85.9	7.16	14.4	21.6	28.5	50.1	71.6	100.0	
	[oz・in]	3458	4875	8120	12173	1015	2041	3061	4039	7100	10146	14171	
Power rate at continuous rated torque	[kW/s]	32.9	30.9	44.5	81.3	8.7	16.7	25.6	21.5	34.1	56.5	69.7	
Inertia moment (Note 3)	J [ $\times 10^{-4}$ kg・m <sup>2</sup> ]	20.0	42.5	82	101	6.6	13.7	20.0	4.5	82.0	101	160	
	WK <sup>2</sup> [oz・in <sup>2</sup> ]	109	232	448	552	36.1	74.9	109	232	448	552	875	
Recommended ratio of load inertia moment to servo motor shaft inertia moment (Note 2)		15 times or less				15 times or less							
Regenerative brake duty [times/min] (Note 4)	MR-J 2S series	Servo amplifier* built-in regenerative brake resistor	140	240	100	84	56	54	136	64	31	39	32
		MR-RB032(30W)	220				165	80					
		MR-RB12(100W)	740				560	270					
		MR-RB32(300W)	2220					810					
		MR-RB30(300W)		730	330	250			408	192	95	90	
		MR-RB50(500W)		1216	550	430			680	320	158	150	
		MR-RB31(300W)											57
MR-RB51(500W)											95		
Power supply capacity		Refer to "Power supply equipment capacity and generated loss of servo amplifiers" in Servo Amplifier Instruction Manual.											
Rated current	[A]	5.1	7.1	9.6	16	3.2	6	9	11	17	28	35	
Maximum current	[A]	15.3	21.3	28.8	48	9.6	18	27	33	51	84	105	
Speed/position detector		Encoder (resolution: 131072 pulse/rev)				Encoder (resolution: 131072 pulse/rev)							
Accessories		Encoder・Oil seal				Encoder・Oil seal							
Insulation class		Class F				Class F							
Structure		Totally-enclosed, self-cooled (protection type: IP65)				Totally-enclosed, self-cooled (protection type: IP65(Note 12))							
Environmental conditions (Note 7)		Refer to section 2.1				Refer to section 2.1							
Weight (Note 3)	[kg]	9.0	12	19	23	5.0	7.0	9.0	12.0	19.0	23	32	
	[lb]	19.8	26.5	41.9	50.7	11.0	15.4	19.8	26.5	41.9	50.7	70.5	

## 5. SPECIFICATIONS

Servo Motor		HC-SFS 3000r/min Series (middle inertia · middle capacity)					HC-RFS Series (ultra low inertia · middle capacity)					
		53	103	153	203	353	103	153	203	353	503	
Applicable servo amplifier	MR-J 2S-□A/B/CP	60	100	200	200	350	200	200	350	500	500	
Continuous characteristics (Note 1 · 11)	Rated output [kW]	0.5	1.0	1.5	2.0	3.5	1.0	1.5	2.0	3.5	5.0	
	Rated torque	[N · m]	1.59	3.18	4.78	6.37	11.1	3.18	4.78	6.37	11.1	15.9
		[oz · in]	225	451	677	903	1573	451	677	903	2253	
Rated speed (Note 1)		[r/min]	3000					3000				
Maximum speed		[r/min]	3000					4500				
Instantaneous permissible speed		[r/min]	3450					5175				
Maximum torque		[N · m]	4.77	9.55	14.3	19.1	33.4	7.95	11.9	15.9	27.9	39.7
		[oz · in]	676	1353	2026	2707	4733	1127	1686	2253	3954	5626
Power rate at continuous rated torque		[kW/s]	3.8	7.4	11.4	9.5	15.1	67.4	120	176	150	211
Inertia moment (Note 3)	J	[ $\times 10^{-4}$ kg · m <sup>2</sup> ]	6.6	13.7	20.0	42.5	82.0	1.5	1.9	2.3	8.6	12.0
	WK <sup>2</sup>	[oz · in <sup>2</sup> ]	36.1	74.9	109.3	232.4	448.3	8.2	10.4	12.6	47.0	65.6
Recommended ratio of load inertia moment to servo motor shaft inertia moment (Note 2)			15 times or less					5 times or less				
Regenerative brake duty (times/min) (Note 4)	MR-J 2S series	Servo amplifier built-in regenerative brake resistor	25	24	82	24	14	1090	860	710	174	125
		MR-RB032(30W)	73	36								
		MR-RB12(100W)	250	120								
		MR-RB32(300W)		360								
		MR-RB30(300W)			250	70	42	3270	2580	2130	401	
		MR-RB50(500W)			410	110	70	5450	4300	3550	669	
		MR-RB31(300W)										288
											479	
Power supply capacity		Refer to "Power supply equipment capacity and generated loss of servo amplifiers" in Servo Amplifier Instruction Manual.										
Rated current	[A]	3.2	5.3	8.6	10.4	16.4	6.1	8.8	14	23	28	
Maximum current	[A]	9.6	15.9	25.8	31.2	49.2	18.4	23.4	37	58	70	
Speed/position detector		Encoder (resolution : 131072 pulse/rev)					Encoder (resolution : 131072 pulse/rev)					
Accessories		Encoder · Oil seal					Encoder · Oil seal					
Insulation class		Class F					Class F					
Structure		Totally-enclosed, self-cooled (protection type: IP65)					Totally-enclosed, self-cooled (protection type: IP65(Note 12))					
Environmental conditions (Note 7)		Refer to section 2.1					Refer to section 2.1					
Weight (Note 3)	[kg]	5.0	7.0	9.0	12	19	3.9	5.0	6.2	12.0	17.0	
	[lb]	11.0	15.4	19.8	26.5	41.9	8.6	11.0	13.7	26.5	37.5	

## 5. SPECIFICATIONS

Servo Motor		HC-UFS 2000r/min Series (pancake type · middle capacity)					HC-UFS 3000r/min Series (pancake type · small capacity)				
		72	152	202	352	502	13	23	43	73	
Applicable servo amplifier/drive unit	MR-J 2S □A/B/CP	70	200	350	500	500	10	20	40	70	
	MR-J 2M □DU						10	20	40	70	
Continuous characteristics (Note 1 · 11)	Rated output [kW]	0.75	1.5	2.0	3.5	5.0	0.1	0.2	0.4	0.75	
	Rated torque	[N · m]	3.58	7.16	9.55	16.7	23.9	0.32	0.64	1.3	2.4
		[oz · in]	507	1015	1353	2367	3387	45	91	184	340
Rated speed (Note 1)	[r/min]	2000					3000				
Maximum speed	[r/min]	3000			2500		4500				
Instantaneous permissible speed	[r/min]	3450			2875		5175				
Maximum torque	[N · m]	10.7	21.6	28.5	50.1	71.6	0.95	1.9	3.8	7.2	
	[oz · in]	1516	3061	4039	7100	10146	135	269	538	1020	
Power rate at continuous rated torque	[kW/s]	12.3	23.2	23.9	36.5	49.6	15.5	19.2	47.7	9.66	
Inertia moment (Note 3)	J [ $\times 10^{-4}$ kg · m <sup>2</sup> ]	10.4	22.1	38.2	76.5	115	0.066	0.241	0.365	5.90	
	WK <sup>2</sup> [oz · in <sup>2</sup> ]	56.9	120.8	208.9	418.3	628.8	0.4	1.3	2.0	32.3	
Recommended ratio of load inertia moment to servo motor shaft inertia moment (Note 2)		15 times or less					15 times or less				
Regenerative brake duty (times/min) (Note 4)	MR-J 2S series	Servo amplifier built-in regenerative brake resistor	53	124	68	44	31	(Note5)	(Note5)	410	41
		MR-RB032(30W)	79							1230	62
		MR-RB12(100W)	87							4106	206
		MR-RB30(300W)		372	203	109	72				
		MR-RB50(300W)		620	338	169	119				
Power supply capacity		Refer to "Power supply equipment capacity and generated loss of servo amplifiers" in Servo Amplifier Instruction Manual.									
Rated current	[A]	5.4	9.7	14	23	28	0.76	1.5	2.8	4.3	
Maximum current	[A]	16.2	29.1	42	69	84	2.5	4.95	9.24	12.9	
Speed/position detector		Encoder (resolution : 131072 pulse/rev)					Encoder (resolution : 131072 pulse/rev)				
Accessories		Encoder · Oil seal					Encoder · Oil seal				
Insulation class		Class F					Class B				
Structure		Totally-enclosed, self-cooled (protection type: IP65(Note9))					Totally-enclosed, self-cooled (protection type: IP65(Note9))				
Environmental conditions (Note 7)		Refer to section 2.1					Refer to section 2.1				
Weight (Note 3)	[kg]	8.0	11.0	16.0	20.0	24.0	0.8	1.5	1.7	5.0	
	[lb]	17.6	24.3	35.3	44.1	52.9	1.8	3.3	3.7	11.0	

## 5. SPECIFICATIONS

Item		Servo Motor	HA-LFS 1000r/min Series (low inertia · large capacity)							
			601 (Note 13)	801	12K1	15K1	20K1	25K1	30K1	37K1
Applicable servo amplifier	MR-J 2S-□A/B	700	11K		15K	22K		30K	37K	
	MR-J 2S-□CP	700								
Compatible converter unit		MR-HP30K A								
Continuous characteristics (Note 1 · 11)	Rated output [kW]	6	8	12	15	20	25	30	37	
	Rated torque	[N · m]	57.3	76.4	115	143	191	239	286	353
		[oz · in]	8114	10819	16285	20251	27048	33845	40501	49989
Rated speed (Note 1)		[r/min]	1000							
Maximum speed		[r/min]	1200							
Instantaneous permissible speed		[r/min]	1380							
Maximum torque	[N · m]	172	229	344	415	477	597	716	883	
	[oz · in]	24357	32429	48715	58769	67549	84542	101394	125044	
Power rate at continuous rated torque		[kW/s]	313	265	445	373	561	528	626	668
Inertia moment (Note 3)	J [ $\times 10^{-4}$ kg · m <sup>2</sup> ]	105	220	295	550	650	1080	1310	1870	
	WK <sup>2</sup> [oz · in <sup>2</sup> ]	574.1	1202.8	1612.9	3007.1	3553.8	5904.8	7162.4	10224.1	
Recommended ratio of load inertia moment to servo motor shaft inertia moment (Note 2)		10 times or less								
Regenerative brake duty (times/min) (Note 4)	Servo amplifier' built-in regenerative brake resistor	158								
	MR-RB31(300W)	278								
	MR-RB51(500W)	464								
	MR-RB65(800W)		354	264						
	MR-RB66(1300W)				230					
	MR-RB67(1300W)					195	117			
	MR-RB139(1300W)							97	68	
	MR-RB137(3900W)							290	203	
Power supply capacity		Refer to "power supply equipment capacity and generated loss of servo amplifiers" in Servo Amplifier Instruction Manual.								
Rated current [A]		34	42	61	83	118	118	154	188	
Maximum current [A]		102	126	183	249	295	295	385	470	
Speed/position detector		Encoder (resolution: 131072 pulse/rev)								
Cooling fan	Power supply	Voltage · frequency	Three-phase 200 to 220 VAC 50Hz, One-phase 200 to 230 VAC 60Hz		Three-phase 200 to 220VAC 50Hz Three-phase 200 to 230VAC 60Hz					
		Power consumption [W]	42(50Hz)/ 54(60Hz)	32(50Hz)/ 40(60Hz)	45(50Hz)/ 63(60Hz)	120(50Hz)/ 175(60Hz)				
	Rated current [A]	0.21(50Hz)/ 0.25(60Hz)	0.30(50Hz)/ 0.25(60Hz)	0.32(50Hz)/ 0.35(60Hz)	0.65(50Hz)/ 0.80(60Hz)					
Accessories		Absolute · Encoder, oil seal								
Insulation class		Class F								
Structure		Totally-enclosed, force-cooled (protection type: IP44)								
Environmental conditions (Note 7)		Refer to Section 2.1								
Weight (Note 3)	[kg]	55	95	115	160	180	230	250	335	
	[lb]	121.3	209.4	253.5	352.7	396.8	507.1	551.6	738.5	



## 5. SPECIFICATIONS

Servo Motor		HA-LFS 1500r/min Series (low inertia · large capacity)						
		701M (Note 13)	11K1M	15K1M	22K1M	30K1M	37K1M	
Applicable servo amplifier	MR-J 2S-□A/B	700	11K	15K	22K	30K	37K	
	MR-J 2S-□CP	700						
Compatible converter unit		MR-HP30KA						
Continuous characteristics (Note 1 · 11)	Rated output [kW]	7	11	15	22	30	37	
	Rated torque	[N · m] [oz · in]	44.6 6315.9	70.0 9912.9	95.5 13524	140 19825.7	191 27047.9	236 33420.5
Rated speed (Note1)		[r/min]	1500					
Maximum speed		[r/min]	2000					
Instantaneous permissible speed		[r/min]	2300					
Maximum torque	[N · m]	134	210	286	350	477	589	
	[oz · in]	18976	29738.6	40501.1	49564.3	67549.1	83409.6	
Power rate at continuous rated torque		[kW/s]	189	223	309	357	561	514
Inertia moment (Note 3)	J [ $\times 10^{-4}$ kg · m <sup>2</sup> ]	105	220	295	550	650	1080	
	WK <sup>2</sup> [oz · in <sup>2</sup> ]	574.1	1202.8	1612.9	3007.1	3553.8	5904.8	
Recommended ratio if load inertia moment to servo motor shaft inertia moment (Note 2)		10 times or less						
Regenerative brake duty (times/min) (Note4)	Servo amplifier' built-in regenerative brake resistor	70						
	MR-RB31(300W)	124						
	MR-RB51(500W)	206						
	MR-RB65(800W)		158					
	MR-RB66(1300W)			191				
	MR-RB67(1300W)				102			
	MR-RB139(1300W)					87	52	
MR-RB137(3900W)					260	156		
Power supply capacity		Refer to "power supply equipment capacity and generated loss of servo amplifiers" in Servo Amplifier Instruction Manual.						
Rated current		[A]	37	65	87	126	174	202
Maximum current		[A]	111	195	261	315	435	505
Speed/position detector		Encoder (resolution: 131072 pulse/rev)						
cooling fan	Power supply	Voltage · frequency	One-phase 200 to 220 VAC 50Hz, One-phase 200 to 230 VAC 60Hz	Three-phase 200 to 220VAC 50Hz Three-phase 200 to 230VAC 60Hz				
		Power consumption [W]	42(50Hz)/ 54(60Hz)	32(50Hz)/ 40(60Hz)	45(50Hz)/ 63(60Hz)	120(50Hz)/ 175(60Hz)		
	Rated current [A]	0.21(50Hz)/ 0.25(60Hz)	0.30(50Hz)/ 0.25(60Hz)	0.32(50Hz)/ 0.35(60Hz)	0.65(50Hz)/ 0.80(60Hz)			
Accessories		Absolute · Encoder, oil seal						
Insulation class		Class F						
Structure		Totally-enclosed, force-cooled (protection type: IP44)						
Environmental conditions (Note 7)		Refer to Section 2.1						
Weight (Note 3)	[kg]	55	95	115	160	180	230	
	[lb]	121.3	209.4	253.5	352.7	396.8	507.1	

## 5. SPECIFICATIONS

Servo Motor		HA-LFS 2000r/min Series (low inertia · large capacity)						
		502 (Note 13)	702 (Note 13)	11K2	15K2	22K2	30K2	37K2
Applicable servo amplifier	MR-J 2S-□A/B	500	700	11K	15K	22K	30K	37K
	MR-J 2S-□CP	500	700					
Compatible converter unit							MR-HP30KA	
Continuous characteristics (Note 1 · 11)	Rated output [kW]	5.0	7.0	11	15	22	30	37
	Rated torque							
	[N · m]	23.9	33.4	52.5	71.6	105	143	177
	[oz · in]	3384.5	4729.9	7434.6	10139.4	14869.3	20250.6	25065.4
Rated speed (Note 1)		[r/min] 2000						
Maximum speed		[r/min] 2000						
Instantaneous permissible speed		[r/min] 2300						
Maximum torque	[N · m]	71.6	100	158	215	263	358	442
	[oz · in]	10139.4	14161.2	22374.7	30446.6	37244	50697.2	62592.6
Power rate at continuous rated torque		[kW/s] 77.2	118	263	233	374	373	480
Inertia moment (Note 3)	J [ $\times 10^{-4}$ kg · m <sup>2</sup> ]	74.0	94.2	105	220	295	550	650
	WK <sup>2</sup> [oz · in <sup>2</sup> ]	404.6	515	574.1	1202.8	1612.9	3007.1	3553.8
Recommended ratio of load inertia moment to servo motor shaft inertia moment (Note 2)		10 times or less						
Regenerative brake duty [times/min] (Note 4)	Servo amplifier' built-in regenerative brake resistor	50	50					
	MR-RB30(300W)	120						
	MR-RB31(300W)		95					
	MR-RB50(500W)	200						
	MR-RB51(500W)		160					
	MR-RB65(800W)			186				
	MR-RB66(1300W)				144			
	MR-RB67(1300W)					107		
	MR-RB139(1300W)					58	49	
	MR-RB137(3900W)					174	147	
Power supply capacity		Refer to "power supply equipment capacity and generated loss of servo amplifiers" in Servo Amplifier Instruction Manual.						
Rated current [A]		25	34	63	77	112	166	204
Maximum current [A]		75	102	189	231	280	415	510
Speed/position detector		Encoder (resolution: 131072 pulse/rev)						
Cooling fan	Power supply	Voltage · frequency			One-phase 200 to 220 VAC 50Hz, One-phase 200 to 230 VAC 60Hz	Three-phase 200 to 220VAC 50Hz Three-phase 200 to 230VAC 60Hz		
		Power consumption [W]			42(50Hz)/ 54(60Hz)	32(50Hz)/ 40(60Hz)	40(50Hz)/ 63(60Hz)	
	Rated current [A]			0.21(50Hz)/ 0.25(60Hz)	0.30(50Hz)/ 0.25(60Hz)	0.32(50Hz)/ 0.35(60Hz)		
Accessories		Absolute · Encoder, oil seal						
Insulation class		Class F						
Structure		Totally-enclosed, self-cooled (protection: IP65)			Totally-enclosed, force-cooled (protection: IP44)			
Environmental conditions (Note 7)		Refer to Section 2.1						
Weight (Note 3)	[kg]	28	35	55	95	115	160	180
	[lb]	61.7	77.2	121.3	209.4	253.5	352.7	396.8

## 5. SPECIFICATIONS

Servo Motor		HC-LFS Series (low inertia · middle capacity)				
Item		52	102	152	202	302
Applicable servo amplifier	MR-J 2S-□	60A-U026	100A-U027	200A-U028	350A-U029	500A-U029
		60B-U026	100B-U027	200B-U028	350B-U029	500B-U029
		60CP-U026	100CP-U027	200CP-U028	350CP-U029	500CP-U029
Continuous characteristics (Note 1 · 11)	Rated output [kW]	0.5	1.0	1.5	2.0	3.0
	Rated torque	[N · m]	2.39	4.78	7.16	9.55
[oz · in]		338.5	676.9	1013.9	1352.4	2025.1
Rated speed (Note 1)		[r/min] 2000				
Maximum speed		[r/min] 3000				
Instantaneous permissible speed		[r/min] 3450				
Maximum torque	[N · m]	7.16	14.4	21.6	28.5	42.9
	[oz · in]	1013.9	2039.2	3058.8	4036	6075.2
Power rate at continuous rated torque		[kW/s] 17.9	49.7	80.1	41.5	56.8
Inertia moment (Note 3)	J [ $\times 10^{-4}$ kg · m <sup>2</sup> ]	3.2	4.6	6.4	22	36
	WK <sup>2</sup> [oz · in <sup>2</sup> ]	17.5	25.2	35	120.3	196.8
Recommended ratio of load inertia moment to servo motor shaft inertia moment (Note 2)		10 times or less				
Regenerative brake duty [times/min] (Note 4)	Servo amplifier' built-in regenerative brake resistor	115	160	425	120	70
	MR-RB032(30W)	340	235			
	MR-RB12(100W)	1150	800			
	MR-RB30(300W)			1270	370	215
	MR-RB32(300W)		2410			
MR-RB50(500W)			2120	615	355	
Power supply capacity		Refer to "power supply equipment capacity and generated loss of servo amplifiers" in Servo Amplifier Instruction Manual.				
Rated current [A]		3.2	5.9	9.9	14	23
Maximum current [A]		9.6	18	30	42	69
Speed/position detector		Encoder (resolution: 131072 pulse/rev)				
Accessories		Absolute · Encoder · oil seal				
Insulation class		Class F				
Structure		Totally-enclosed, self-cooled (protection type: IP65)				
Environmental conditions (Note 7)		Refer to Section 2.1				
Weight (Note 3)	[kg]	6.5	8.0	10.0	21	28
	[lb]	14.33	17.6	22	46.3	61.7

## 5. SPECIFICATIONS

---

- Note: 1. When the power supply voltage drops, we cannot guarantee the output and rated speed.  
2. If the load inertia moment ratio exceeds the indicated value, please consult us.  
3. When the servo motor is equipped with reduction gear or electromagnetic brake, refer to the corresponding outline dimension drawing. For the EN Standard- and UL/C-UL Standard-compliant models, please consult us.  
4. The regenerative brake duty indicated is the permissible duty when the servo motor running without load at the rated speed is decelerated to a stop. When a load is connected, the value in the table is multiplied by  $1/(m + 1)$ , where  $m = \text{load inertia moment/motor inertia moment}$ . At the speed higher than the rated, the permissible number of times is in inverse proportion to the square of (running speed/rated speed). When the running speed varies frequently or when the regenerative mode continues as in vertical feed, calculate regenerative heat generated during operation. Provisions must be made to keep this generated heat below the permissible value.  
5. If the effective torque is within the rated torque range, there are no restrictions on the regenerative duty.  
6. Except for the shaft-through portion and connector end.  
7. In the environment where the servo motor is exposed to oil mist, oil and/or water, the servo motor of the standard specifications may not be usable. Contact us.  
8. IP54 for the EN Standard-compliant model.  
9. Except the connector section.  
10. Values for use of the supplied regenerative brake unit (regenerative brake resistor).  
11. 80%ED at low noise.

80%ED: Indicates the condition in which operation time at rated torque accounts for 80% and the other no-load time accounts for 20% in a single operation cycle.

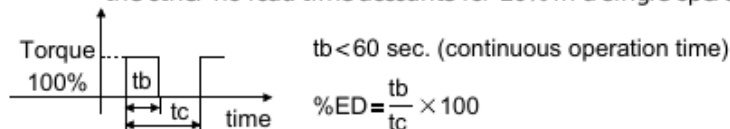

12. When the servo motor is provided with the reduction gear, the protection type of the reduction gear section is IP44.  
13. Consult us since they may not be connected depending on the production period of the servo amplifier.

## 5. SPECIFICATIONS

### 5.2 Torque characteristics

**POINT**

• For machines which produce unbalance torque, e.g. vertical lift applications, it is recommended to use the servo motor so that the unbalance torque will be within 70% of the rated torque.

#### (1) HC-MF series

**POINT**

The continuous broken line in the graph assumes that the servo motor is used with the servo amplifier of single-phase 100VAC power supply specifications.

[HC-MF053]

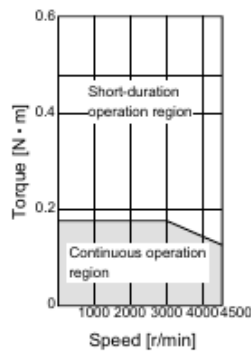

[HC-MF13]

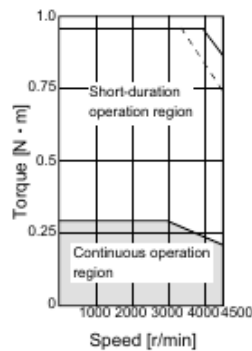

[HC-MF23]

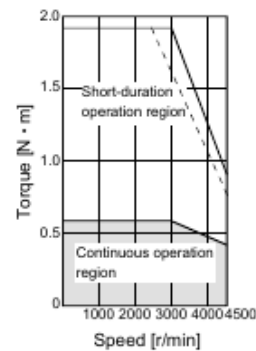

[HC-MF43]

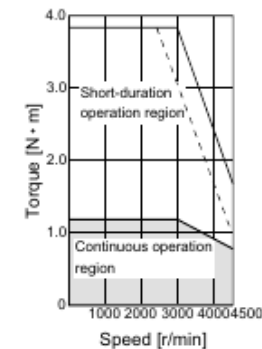

[HC-MF73]

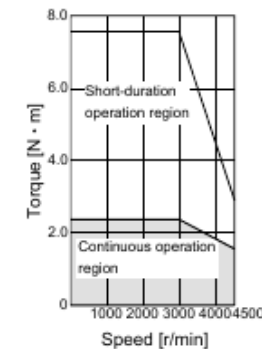

#### (2) HA-FF series

**POINT**

The continuous broken line in the graph assumes that the servo motor is used with the servo amplifier of single-phase 100VAC power supply specifications.

[HA-FF053]

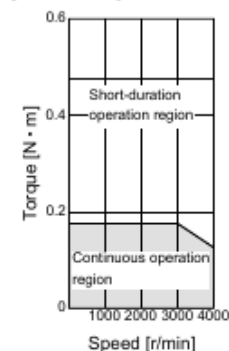

[HA-FF13]

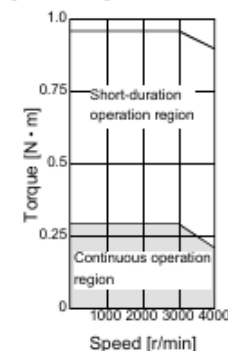

[HA-FF23]

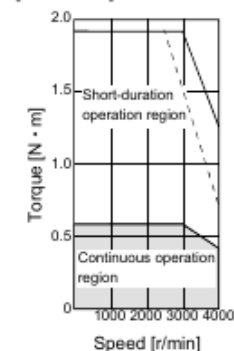

## 5. SPECIFICATIONS

[HA-FF33]

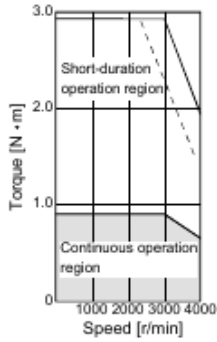

[HA-FF43]

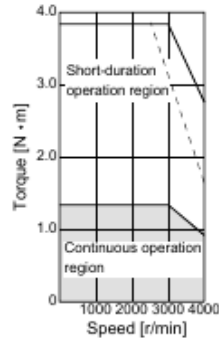

[HA-FF63]

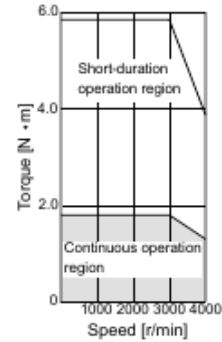

### (3) HC-SF/HC-SFS series

[HC-SF81]

[HC-SFS81]

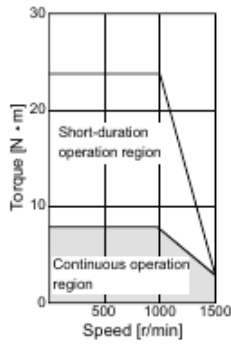

[HC-SF121]

[HC-SFS121]

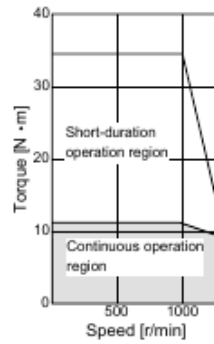

[HC-SF201]

[HC-SFS201]

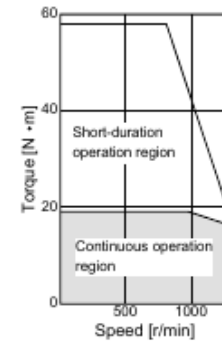

[HC-SF301]

[HC-SFS301]

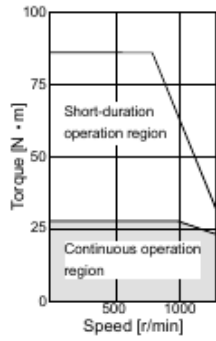

[HC-SF52]

[HC-SFS52]

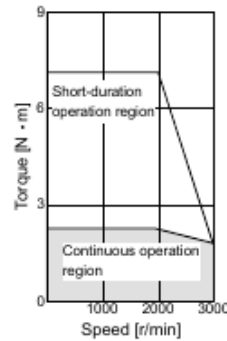

[HC-SF102]

[HC-SFS102]

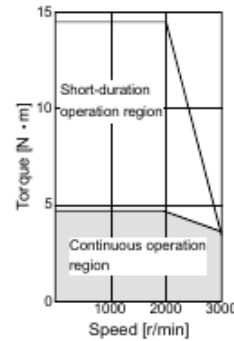

[HC-SF152]

[HC-SFS152]

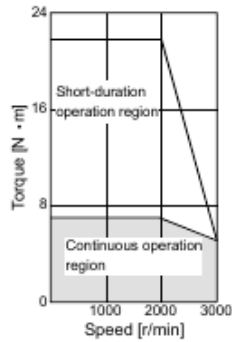

[HC-SF202]

[HC-SFS202]

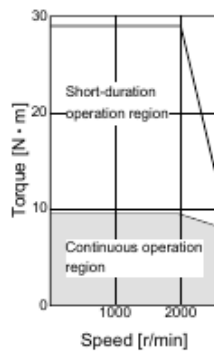

[HC-SF352]

[HC-SFS352]

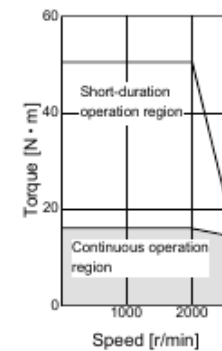

## 5. SPECIFICATIONS

[HC-SF502]  
[HC-SFS502]

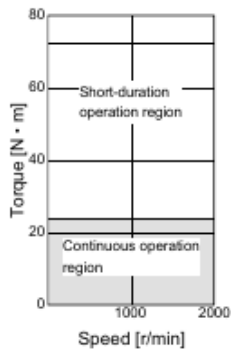

[HC-SF702]  
[HC-SFS702]

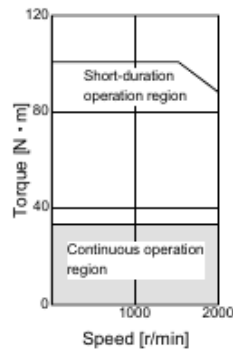

[HC-SF53]  
[HC-SFS53]

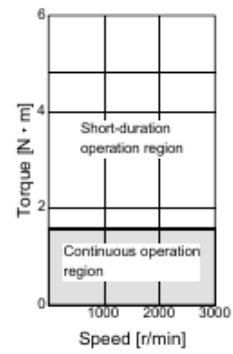

[HC-SF103]  
[HC-SFS103]

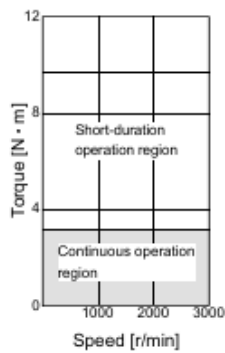

[HC-SF153]  
[HC-SFS153]

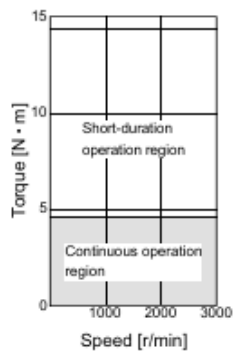

[HC-SF203]  
[HC-SFS203]

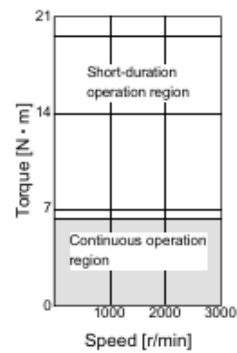

[HC-SF353]  
[HC-SFS353]

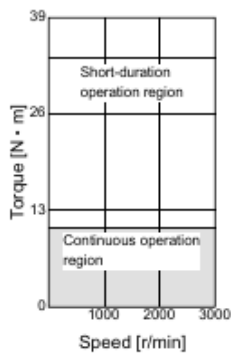

## 5. SPECIFICATIONS

### (4) HC-RF/HC-RFS series

[HC-RF103]  
[HC-RFS103]

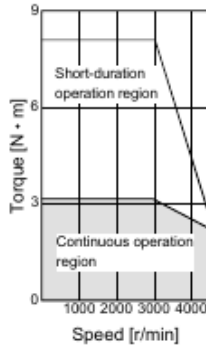

[HC-RF153]  
[HC-RFS153]

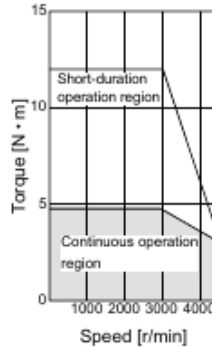

[HC-RF203]  
[HC-RFS203]

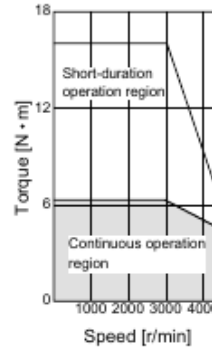

[HC-RF353]  
[HC-RFS353]

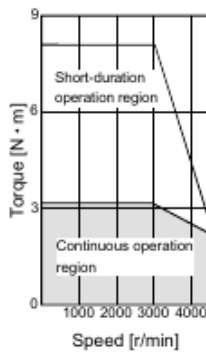

[HC-RF503]  
[HC-RFS503]

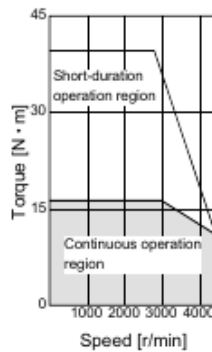

### (5) HC-UF/HC-UFS series

#### POINT

The continuous broken line in the graph assumes that the servo motor is used with the servo amplifier of single-phase 100VAC power supply specifications.

[HC-UF72]  
[HC-UFS72]

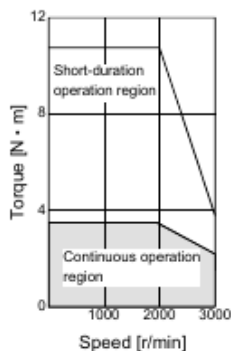

[HC-UF152]  
[HC-UFS152]

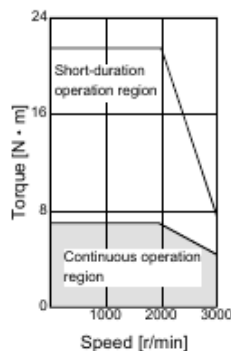

[HC-UF202]  
[HC-UFS202]

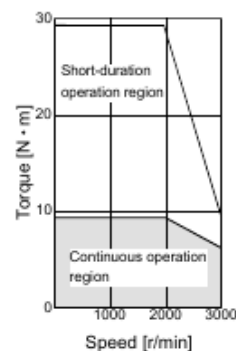



## 5. SPECIFICATIONS

[HC-UF352]  
[HC-UFS352]

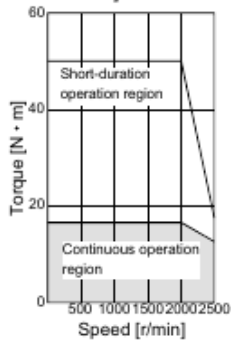

[HC-UF502]  
[HC-UFS502]

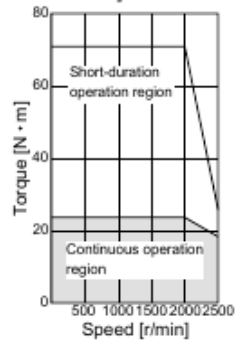

[HC-UF13]

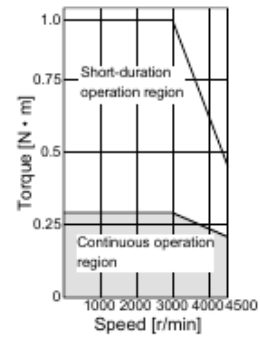

[HC-UF23]

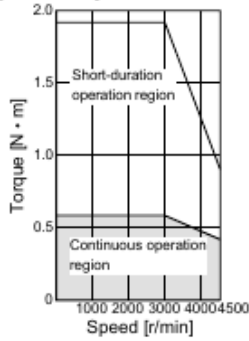

[HC-UF43]

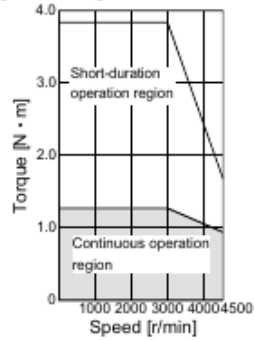

[HC-UF73]

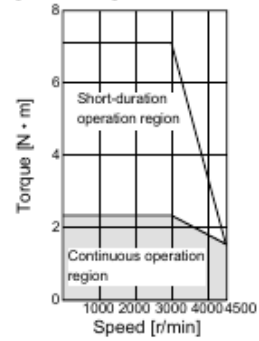

[HC-UFS13]

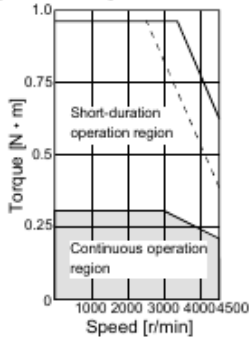

[HC-UFS23]

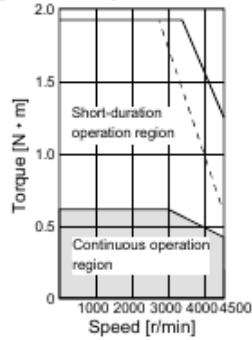

[HC-UFS43]

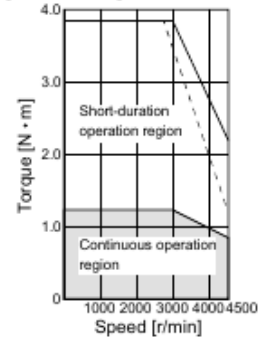

[HC-UFS73]

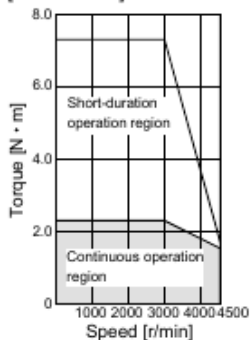

## 5. SPECIFICATIONS

### (6) HA-LH series

[HA-LH11K2]

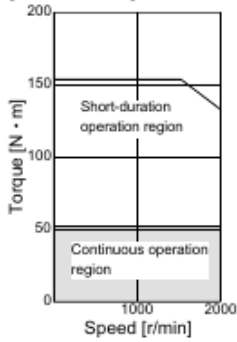

[HA-LH15K2]

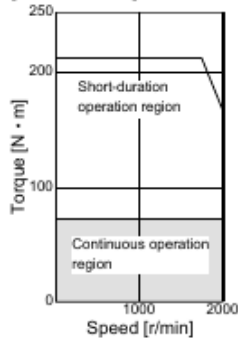

[HA-LH22K2]

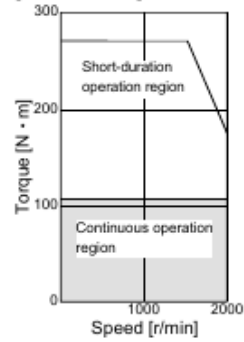

### (7) HC-KF series

[HC-KF053]

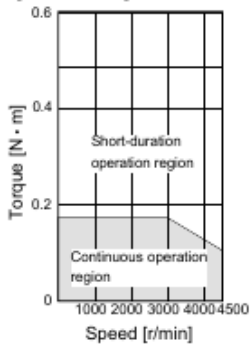

[HC-KF13]

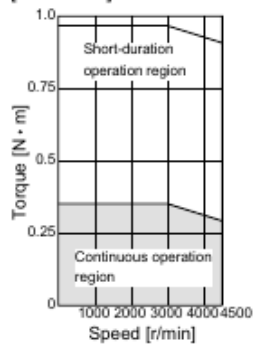

[HC-KF23]

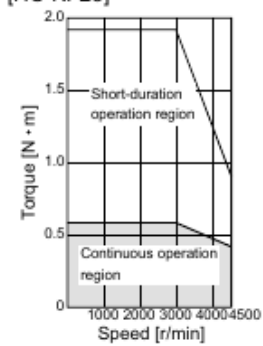

[HC-KF43]

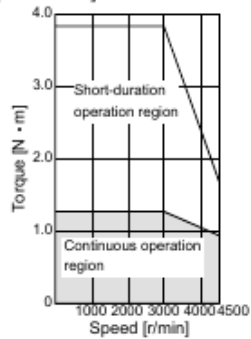

## 5. SPECIFICATIONS

### (8) HC-AQ series

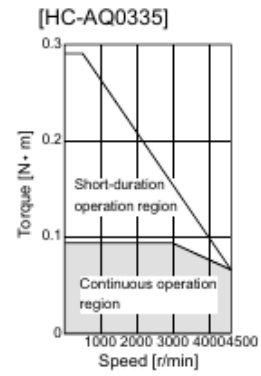
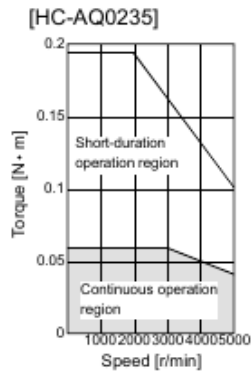
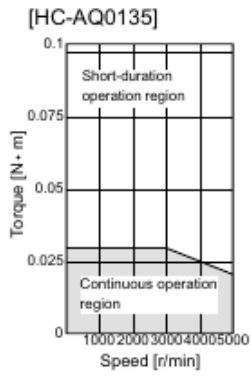

### (9) HA-LF series

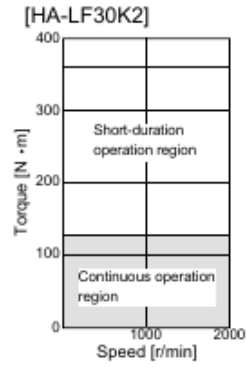
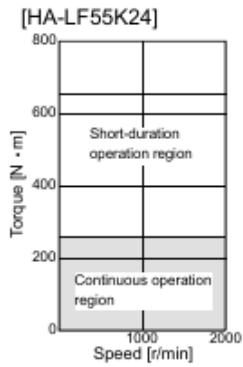
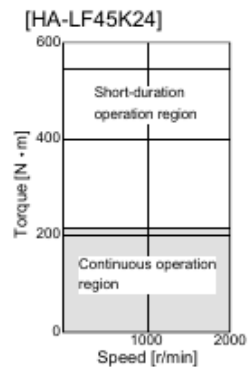
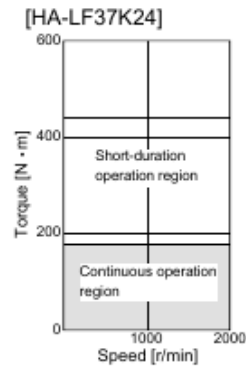
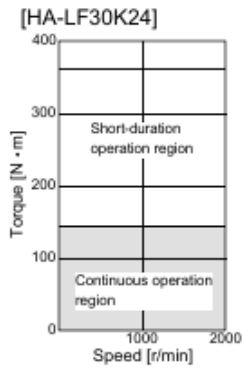

## 5. SPECIFICATIONS

### (10) HA-LFS series

[HA-LFS601]

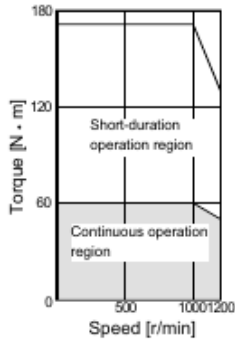

[HA-LFS801]

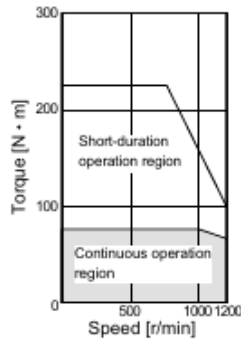

[HA-LFS12K1]

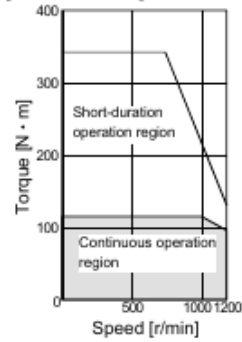

[HA-LFS15K1]

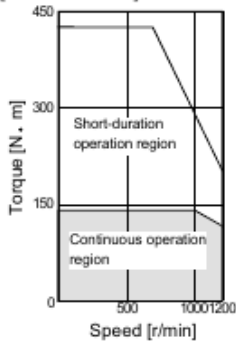

[HA-LFS20K1]

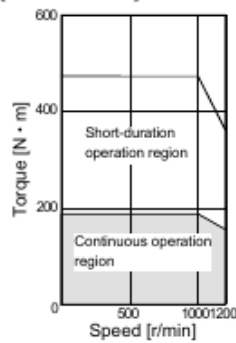

[HA-LFS25K1]

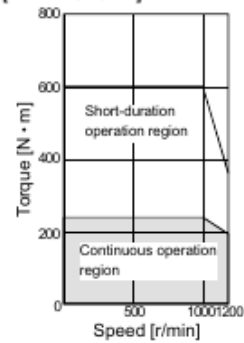

[HA-LFS30K1]

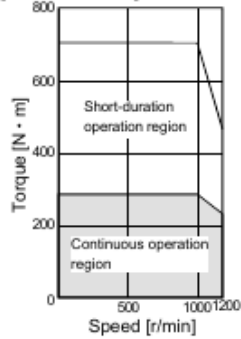

[HA-LFS37K1]

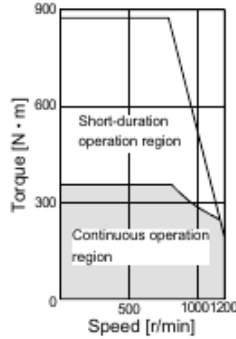

[HA-LFS701M]

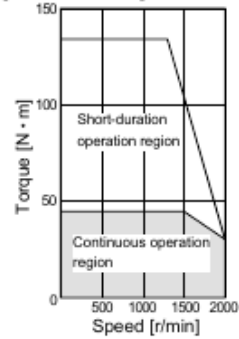

[HA-LFS11K1M]

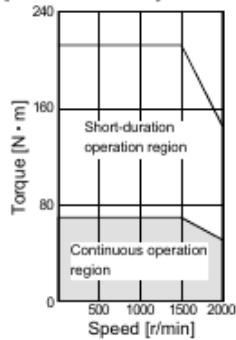

[HA-LFS15K1M]

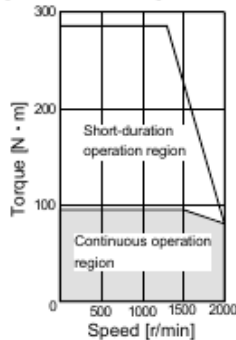

[HA-LFS22K1M]

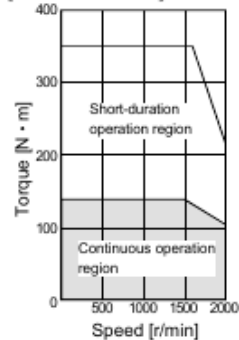

## 5. SPECIFICATIONS

[HA-LFS30K1M]

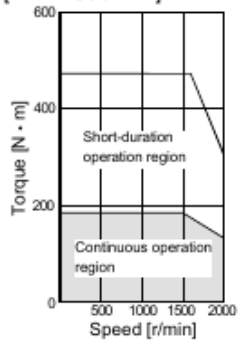

[HA-LFS37K1M]

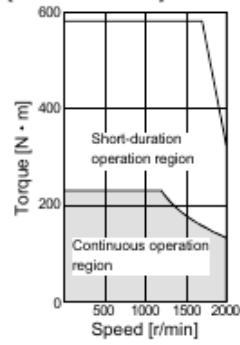

[HA-LFS502]

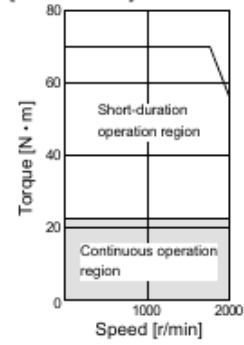

[HA-LFS702]

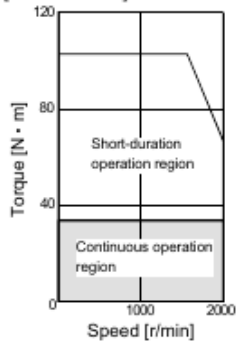

[HA-LFS11K2]

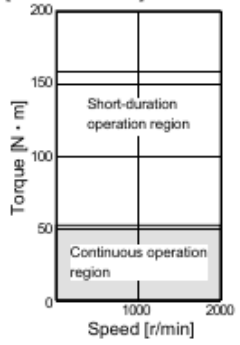

[HA-LFS15K2]

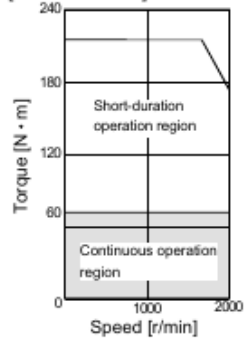

[HA-LFS22K2]

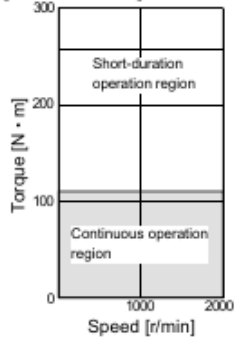

[HA-LFS30K2]

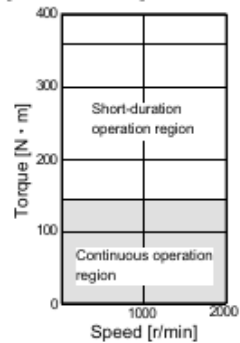

[HA-LFS37K2]

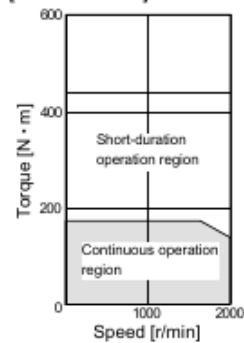

## 5. SPECIFICATIONS

### (11) HC-MFS series

#### POINT

The continuous broken line in the graph assumes that the servo motor is used with the servo amplifier of single-phase 100VAC power supply specifications.

[HC-MFS053]

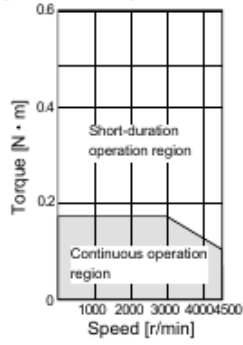

[HC-MFS13]

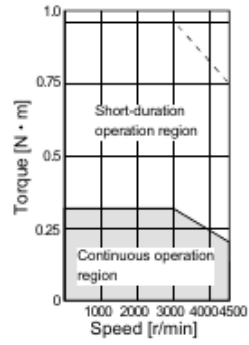

[HC-MFS23]

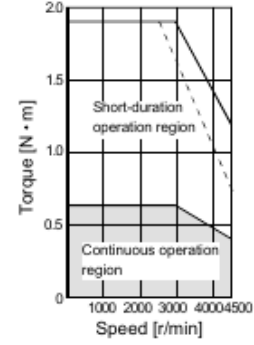

[HC-MFS43]

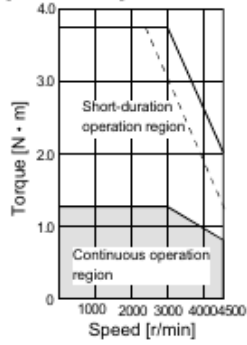

[HC-MFS73]

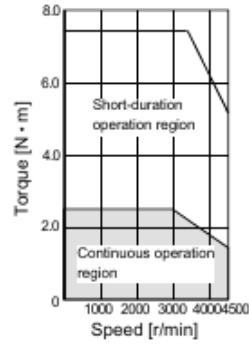

## 5. SPECIFICATIONS

### (12) HC-KFS series

#### POINT

The continuous broken line in the graph assumes that the servo motor is used with the servo amplifier of single-phase 100VAC power supply specifications.

[HC-KFS053]

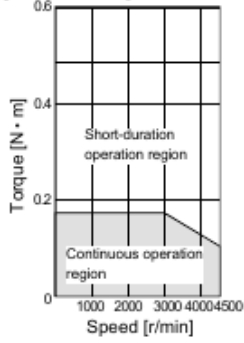

[HC-KFS13]

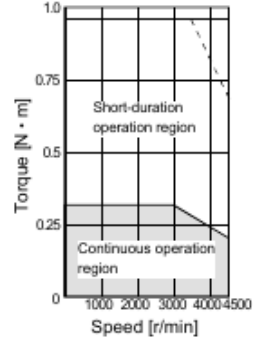

[HC-KFS23]

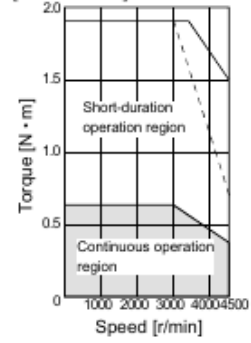

[HC-KFS43]

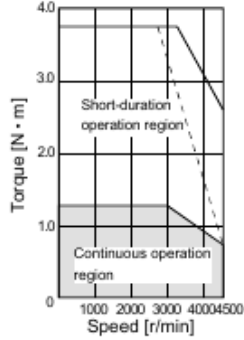

[HC-KFS73]

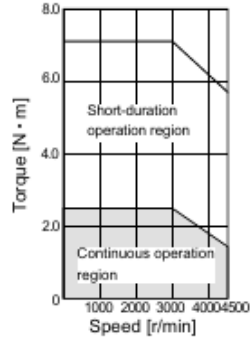

## 5. SPECIFICATIONS

### (13) HC-LFS series

[HC-LFS52]

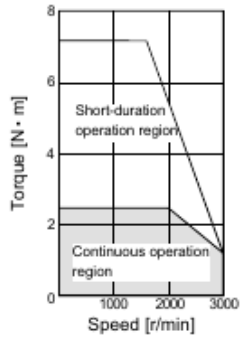

[HC-LFS102]

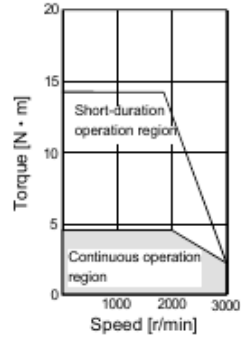

[HC-LFS152]

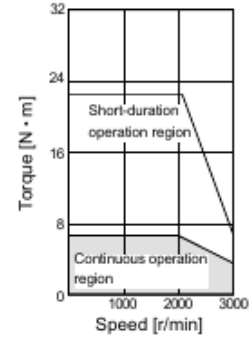

[HC-LFS202]

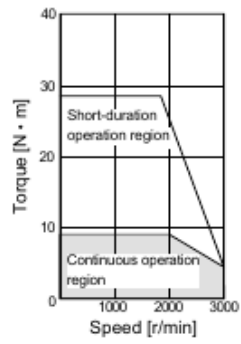

[HC-LFS302]

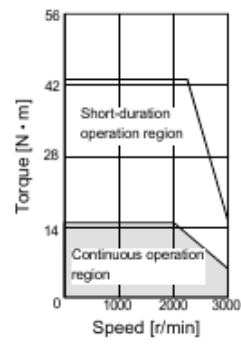



## 5. SPECIFICATIONS

### 5.3 Servo motors with reduction gears

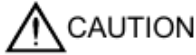

- The servo motor with reduction gear must be installed in the specified direction. Otherwise, it can leak oil, leading to a fire or fault.
- For the servo motor with reduction gear, transport it in the same status as in the installation method. Tipping it over can cause oil leakage.

Servo motors are available with reduction gears designed for: general industrial machines and precision applications.

Servo motors with electromagnetic brakes are also available.

#### (1) Manufacturing range of servo motor with reduction gear

Servo motors with reduction gears that may be manufactured are indicated by symbols (G1(H), G2) in the following table. G1 (H) and G2 are symbols appended to the servo motor models.

Reduction Gear Series Reduction ratio Servo Motor	For General Industrial Machines												For Precision Applications								
	(Note) 1/5	1/6	(Note) 1/10	1/11	(Note) 1/12	1/17	(Note) 1/20	1/29	(Note) 1/30	1/35	1/43	1/59	1/5	1/9	1/10	1/15	1/20	1/25	1/29	1/45	
HC-KF053□ to 43□ HC-KF5053□ to 73□	G1				G1		G1						G2	G2			G2		G2		
HC-MF053□ to 73□ HC-MF5053□ to 73□	G1				G1		G1						G2	G2			G2		G2		
HA-FF053□	G1		G1				G1		G1				G2		G2	G2		G2			
HA-FF13□	G1		G1				G1		G1				G2		G2	G2		G2			G2
HA-FF23□	G1		G1				G1		G1				G2		G2	G2		G2			G2
HA-FF33□	G1		G1				G1		G1				G2		G2	G2		G2			G2
HA-FF43□ · 63□	G1		G1				G1		G1				G2	G2			G2		G2		G2
HC-SF52□ to 202□ HC-SFS52□ to 202□		G1 (H)		G1 (H)		G1 (H)		G1 (H)		G1 (H)	G1 (H)	G1 (H)	G2	G2			G2		G2		G2
HC-SF352□ HC-SFS352□		G1 (H)		G1 (H)		G1 (H)		G1 (H)		G1 (H)	G1 (H)	G1 (H)	G2	G2			G2				
HC-SF502□ HC-SFS502□				G1 (H)		G1 (H)		G1 (H)		G1 (H)	G1 (H)		G2	G2							
HC-SF702□ HC-SFS702□				G1 (H)		G1 (H)		G1 (H)		G1 (H)	G1 (H)		G2								
HC-RF103□ to 203□ HC-RFS103□ to 203□													G2	G2			G2		G2		G2
HC-RF353□ HC-RFS353□													G2	G2			G2		G2		
HC-RF503□ HC-RFS503□													G2	G2			G2				

Note : Reduction ratios for general industrial machines are nominal values. For actual reduction ratios, refer to (2) and (3) in this section.

For those without (Note), the nominal value is equal to the actual reduction ratio.

#### (2) HC-MF/HC-KF series

Reduction Gear Series		For General Industrial Machines (HC-KF□G1/HC-MF□G1) (HC-KFS□G1/HC-MFS□G1)			For Precision Applications (HC-KF□G2/HC-MF□G2) (HC-KFS□G2/HC-MFS□G2)	
Mounting method		Flange mounting				
Mounting direction		In any directions				
Lubrication	Recommended grease	Grease lubrication (Already packed)			Grease lubrication (Already packed)	
		50 · 100W	200W · 400W		750W	LDR101BV American Oil Center Research
			1/12 · 1/20	1/5		
Mobilplex 46 Mobil Oil	New Molynoc No.2 Nisseki Mitsubishi	Mobil Grease SP Mobil Oil				
Output shaft rotating direction		Same as the servo motor output shaft direction.				
With electromagnetic brake		Available				
Backlash		60 minutes or less at reduction gear output shaft			3 minutes or less at reduction gear output shaft	
Permissible load inertia moment ratio (when converting into the servo motor shaft)		HC-KF · HC-KFS:5 times or less HC-MF · HC-MFS:25 times or less				
Permissible speed (at servo motor shaft)		4500 r/min				

## 5. SPECIFICATIONS

The actual reduction ratios of the servo motors with reduction gears designed for general industrial machines are as listed below:

Nominal Reduction Ratio \ Servo Motor	HC-KF053(B)G1	HC-KF13(B)G1	HC-KF23(B)G1	HC-KF43(B)G1	HC-KFS73(B)G1
	HC-MF053(B)G1	HC-MF13(B)G1	HC-MF23(B)G1	HC-MF43(B)G1	HC-MF73(B)G1
	HC-KFS053(B)G1	HC-KFS13(B)G1	HC-KFS23(B)G1	HC-KFS43(B)G1	HC-MFS73(B)G1
	HC-MFS053(B)G1	HC-MFS13(B)G1	HC-MFS23(B)G1	HC-MFS43(B)G1	HC-MFS73(B)G1
1/5	9/44		19/96		1/5
1/12	49/576		25/288		525/6048
1/20	25/484		253/5000		625/12544

### (3) HA-FF series

Reduction Gear Series		For General Industrial Machines (HA-FF□G1)		For Precision Applications (HA-FF□G2)	
Mounting method		Flange mounting			
Mounting direction		In any directions			
Lubrication	Recommended grease	Grease lubrication (Already packed)		Grease lubrication (Already packed)	
		50 - 100W	200 to 600W	LDR101BJ American Oil Center Research	
		SUMICO LUBRICANT MOLY PS GREASE No.2	PYRONOC UNIVERSAL No.000 NIPPON PETROLEUM		
Output shaft rotating direction		Servo motor shaft and reduction gear output shaft rotate in the same direction. For the HA-FF053G1 1/30 and HA-FF3G1 1/30, however, the servo motor shaft and reduction gear output shaft rotate in the opposite directions.		Servo motor shaft and reduction gear output-shaft rotate in the same direction.	
With electromagnetic brake		Available			
Backlash		(Note) 40 minutes to 1.5°		Within 3 minutes	
Permissible load inertia moment ratio (when converting into the servo motor shaft)		5 times or less			
Permissible speed (at servo motor shaft)		3000 r/min			

Note. The above values are typical values and not guaranteed values.

The actual reduction ratios of the servo motors with reduction gears designed for general industrial machines are as listed below:

Nominal Reduction Ratio \ Servo Motor	HA-FF053G1	HA-FF13G1	HA-FF23G1	HA-FF33G1	HA-FF43G1	HA-FF63G1
	1/5	9/44		57/280	19/94	
1/10	3/29		39/400	39/376		243/2401
1/20	99/1972		51/980	72/1363		153/2891
1/30	144/4205		1/30	11/329		27/784

## 5. SPECIFICATIONS

### (4) HC-SF series

Reduction Gear Series		For General Industrial Machines (HC-SF□G1(H)/HC-SFS□G1(H))	For Precision Applications (HC-SF□G2/ HC-SFS□G2)
Mounting method		As in (a) in this section	Flange mounting
Mounting direction		As in (a) in this section	In any directions
Lubrication		As in (a) . (b) in this section	Grease lubrication (Already packed)
	Recommended grease	As in (b) in this section	LDR101B) of American Oil Center Research
Output shaft rotating direction		Opposite direction to the servo motor shaft	Same direction as the servo motor shaft
With electromagnetic brake		Available	
Backlash		40 minutes to 2*at reduction gear output shaft (Note)	3 minutes or less at reduction gear output shaft
Permissible load inertia moment ratio (when converting into the servo motor shaft)		4 times or less	5 times or less
Permissible speed (at servo motor shaft)		2000 r/min	0.5 to 1.5kW:3000 r/min 2 to 3.5kW:2500 r/min 5 - 7kW:2000 r/min

Note. The above values are typical values and not guaranteed values.

#### (a) Lubrication of reduction gears for general industrial machines

Oil lubrication cannot be used in applications where the servo motor will move. Specify grease lubrication.

For grease lubrication, the reduction gear is already grease-packed.

For oil lubrication, pack the reduction gear with oil on the customer side.

Mounting Direction Reduction gear model Reduction gear frame No.	Shaft in Any Direction		Shaft Horizontal		Shaft Downward		Shaft Upward	
	CNHM (leg type)	CNVM (flange type)	CHHM (leg type)	CHVM (flange type)	CVHM (leg type)	CVVM (flange type)	CWHM (leg type)	CWVM (flange type)
4105	Grease	Grease						
4115	Grease	Grease						
4135			(Note) Oil	(Note) Oil	(Note) Oil	(Note) Oil	Grease	Grease
4165			(Note) Oil	(Note) Oil	(Note) Oil	(Note) Oil	Grease	Grease
4175			Oil	Oil	Oil	Oil		
4185			Oil	Oil	Oil	Oil		
4195			Oil	Oil	Oil	Oil		

Note: Grease-lubricated type is also available.

The reduction gear frame numbers are as follows:

Servo Motor	Reduction Ratio						
	1/6	1/11	1/17	1/29	1/35	1/43	1/59
HC-SF 52(B)G1 (H) HC-SFS52(B)G1 (H)	4105			4115			
HC-SF 102(B)G1 (H) HC-SFS102(B)G1 (H)	4115					4135	4165
HC-SF 152(B)G1 (H) HC-SFS152(B)G1 (H)	4115		4135		4165		
HC-SF 202(B)G1 (H) HC-SFS202(B)G1 (H)	4115		4165				
HC-SF 352(B)G1 (H) HC-SFS352(B)G1 (H)	4135		4165		4175		
HC-SF 502(B)G1 (H) HC-SFS502(B)G1 (H)		4165		4185			
HC-SF 702(B)G1 (H) HC-SFS702(B)G1 (H)		4175		4185		4195	

## 5. SPECIFICATIONS

### (b) Recommended lubricants

#### 1) Grease

Albania Grease/Shell OIL

#### 2) Lubricating oil

Ambient Temperature ℃	COSMO OIL	NISSEKI MITSUBISHI OIL	IDEMITSU KOSAN CO., LTD	GENERAL OIL	Shell OIL	ESSO OIL	Mobil OIL	Japan Energy
-10 to 5	COSMO GEAR SE 68	BONNOC SP 68 DIAMOND GEAR LUBE SP 68	DAPHNE CE 685 DAPHNE SUPER GEAR OIL 68		Omala Oils 68	SPARTANEP 68	Mobilgear 626 (ISO VG68)	J O.M.O. Reductus 68
0 to 35	COSMO GEAR SE 100, 150	BONNOC SP 100, 150 DIAMOND GEAR LUBE SP 100 · 150	DAPHNE CE 100S,150S DAPHNE SUPER GEAR OIL 100 · 150	GENERAL SP GEAROL 100 · 150	Omala Oils 100 · 150	SPARTANEP 150	Mobilgear 629 (ISO VG150)	J O.M.O. Reductus 100 · 150
30 to 50	COSMO GEAR SE 200,320,460	BONNOC SP 200 to 460 DIAMOND GEAR LUBE SP 220 to 460	DAPHNE CE 220S to 460S	GENERAL SP GEAROL 200 to 260	Omala Oils 200 to 460	SPARTANEP 220 to 460	Mobilgear 630 to 634 (ISO VG 220 to 460)	J O.M.O. Reductus 200 to 460

#### Lubricating oil fill amount (ℓ)

Reduction gear frame No.	Fill amount [ℓ]	
	Horizontal type	Vertical type
4135	0.7	1.1
4165	1.4	1.0
4175	1.9	1.9
4185	2.5	2.0
4195	4.0	2.7

### (c) Changing intervals of lubricant for general industrial machines

#### 1) Grease:

20000 hours or 3 to 5 years

#### 2) Lubricant

Changing intervals	Operation hours per day	
	Less than 10 hours	10 to 24 hours
First time	500 hours	
Second time and later	Half year	2500 hours

### (5) HC-RF series

Reduction Gear Series	For Precision Applications (HC-RF□G2/HC-RFS□G2)
Mounting method	Flange mounting
Mounting direction	In any directions
Lubrication	Grease lubrication (Already packed)
Recommended grease	LDR101BJ of American Oil Center Research
Output shaft rotating direction	Same direction as the servo motor shaft
With electromagnetic brake	Available
Backlash	Within 3 minutes at reduction gear output shaft
Permissible load inertia moment ratio (when converting into the servo motor shaft)	5 times or less
Permissible speed (at servo motor shaft)	4000 r/min

## 5. SPECIFICATIONS

### 5.4 Servo motors with special shafts

The standard shaft of the servo motor is straight without a keyway. Shafts with keyway and D cut are also available. Except for the servo motor with reduction gear.

These shafts are not appropriate for applications where the servo motor is started and stopped frequently. Use a friction coupling or the like with such keys since we cannot guarantee such trouble as broken shafts due to loose keys.

Servo Motor	Shaft Shape		
	Keyway	D cut	Straight
HC-MF053 · 13 HC-MFS053 · 13	/	○	(Note 3) ○
HC-MF23 to 73 HC-MFS23 to 73		(Note 1) ○	(Note 3) ○
HA-FF053 · 13	/	○	(Note 3) ○
HA-FF23 to 63	(Note 2) ○	/	(Note 3) ○
HC-SF81 to 301 HC-SF52 to 702 HC-SF53 to 353 HC-SFS81 to 301 HC-SFS52 to 702 HC-SFS53 to 353	○	/	(Note 3) ○

Servo Motor Model	Shaft Shape		
	Keyway	D cut	Straight
HC-RF103 to 503 HC-RFS103 to 503	○	/	(Note 3) ○
HC-UF72 to 502 HC-UFS72 to 502	○	/	(Note 3) ○
HC-UF13 HC-UFS13	/	○	(Note 3) ○
HC-UF23 to 73 HC-UFS23 to 73	(Note 1) ○	/	(Note 3) ○
HC-KF053 · 13 HC-KFS053 · 13	/	○	(Note 3) ○
HC-KF23 · 43 HC-KFS23 to 73	(Note 1) ○	/	(Note 3) ○
HC-AQ0135 to 0335	/	(Note 3) ○	○
HC-LFS series	○	/	(Note 3) ○

Note: 1. With a key.

2. Standard with a key. For shape, refer to chapter 7.

3. This is a standard. For shape, refer to chapter 7.

#### 5.4.1 Keyway

(1) With key

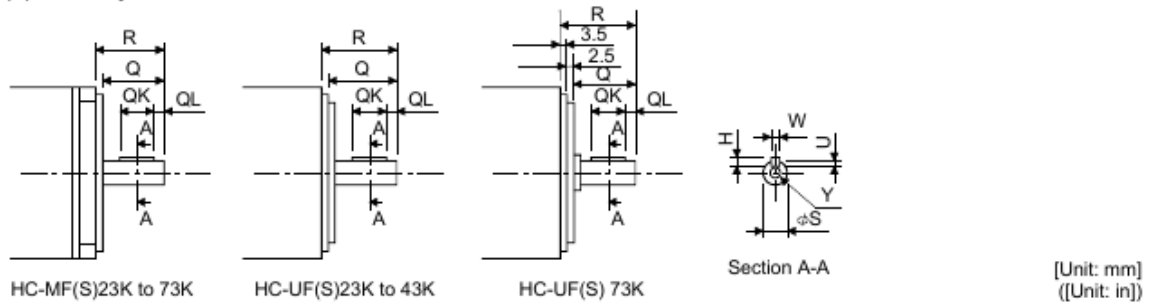

Servo Motor Model	Variable Dimensions								
	S	R	Q	W	QK	QL	U	H	Y
HC-MF23K · 43K HC-MFS23K · 43K	14h6 (14)	30 (1.18)	27 (1.06)	5 (0.20)	20 (0.79)	3 (0.12)	3 (0.12)	5 (0.20)	M4 Depth 15 (0.59)
HC-MF73K HC-MFS73K	19h6 (19)	40 (1.57)	37 (1.46)	6 (0.24)	25 (0.98)	5 (0.20)	3.5 (0.14)	6 (0.24)	M5 Depth 20 (0.79)
HC-UF23K · 43K HC-UFS23K · 43K	14h6 (14)	30 (1.18)	23.5 (0.93)	5 (0.20)	20 (0.79)	3 (0.12)	3 (0.12)	5 (0.20)	M4 Depth 15 (0.59)
HC-UF73K HC-UFS73K	19h6 (19)	40 (1.57)	32.5 (1.28)	6 (0.24)	25 (0.98)	5 (0.20)	3.5 (0.14)	6 (0.24)	M5 Depth 20 (0.79)
HC-KF23K · 43K HC-KFS23K · 43K	14h6 (14)	30 (1.18)	27 (1.06)	5 (0.20)	20 (0.79)	3 (0.12)	3 (0.12)	5 (0.20)	M4 Depth 15 (0.59)
HC-KF73K HC-KFS73K	19h6 (19)	40 (1.57)	37 (1.46)	6 (0.24)	25 (0.98)	5 (0.20)	3.5 (0.14)	6 (0.24)	M5 Depth 20 (0.79)

## 5. SPECIFICATIONS

(2) Without key

[Unit: mm]  
([Unit: in])

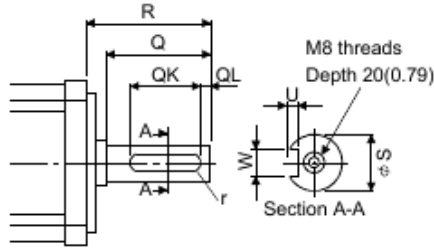

Servo motor	Variable Dimensions							
	S	R	Q	W	QK	QL	U	r
HC-SF81K HC-SF52K to 152K HC-SF53K to 153K HC-SFS81K HC-SFS52K to 152K HC-SFS53K to 153K HC-LFS52 to 152	24h6 (0.94)	55 (2.17)	50 (1.97)	$8^{\circ}_{-0.036}$ (0.31)	36 (1.42)	5 (0.20)	$4^{+0.2}_{0}$ (0.16)	4 (0.16)
HC-SF121K to 301K HC-SF202K to 702K HC-SF203K · 353K HC-SFS121K to 301K HC-SFS202K · 352K HC-SFS203K · 353K HC-LFS202 · 302	$35^{+0.010}_{0}$ (1.38)	79 (3.11)	-	$10^{\circ}_{-0.036}$ (0.39)	55 (2.17)	5 (0.20)	$5^{+0.2}_{0}$ (0.20)	5 (0.20)
HC-RF103K to 203K HC-RFS103K to 203K	24h6 (0.94)	45 (1.77)	40 (1.57)	$8^{\circ}_{-0.036}$ (0.31)	25 (0.98)	5 (0.20)	$4^{+0.2}_{0}$ (0.16)	4 (0.16)
HC-RF353K to 503K HC-RFS353K to 503K	28h6 (1.10)	63 (2.48)	58 (2.28)	$8^{\circ}_{-0.036}$ (0.31)	53 (2.09)	3 (0.12)	$4^{+0.2}_{0}$ (0.16)	4 (0.16)
HC-UF72K HC-UFS72K	22h6 (0.87)	55 (2.17)	50 (1.97)	$6^{\circ}_{-0.030}$ (0.24)	42 (1.65)	3 (0.12)	$3.5^{+0.1}_{0}$ (0.14)	3 (0.12)
HC-UF152K HC-UFS152K	28h6 (1.10)	55 (2.17)	50 (1.97)	$8^{\circ}_{-0.036}$ (0.31)	45 (1.77)	5 (0.20)	$4^{+0.2}_{0}$ (0.16)	4 (0.16)
HC-UF202K to 502K HC-UFS202K to 502K	35h6 (1.38)	65 (2.56)	60 (2.36)	$10^{\circ}_{-0.036}$ (0.39)	55 (2.17)	5 (0.20)	$5^{+0.2}_{0}$ (0.20)	5 (0.20)

5.4.2 D cut

[Unit: mm]  
([Unit: in])

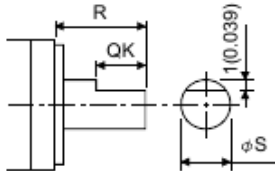

Servo Motor Model	Variable Dimensions		
	R	QK	S
HC-MF053D · 13D HC-KFS053D · 13D HC-MF053D · 13D HC-MFS053D · 13D	25(0.98)	20.5(0.81)	8h(0.32)
HA-FF053D · 13D	30(1.178)	25.5(1.00)	8h(0.32)
HC-UF13D HC-UFS13D	25(0.98)	17.5(0.69)	8h(0.32)

5.4.3 Straight (HC-AQ)

[Unit: mm]  
([Unit: in])

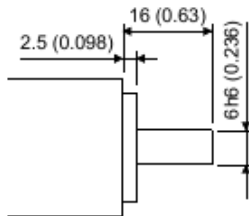



## 6. CHARACTERISTICS

### 6. CHARACTERISTICS

#### 6.1 Electromagnetic brake characteristics



#### CAUTION

- Configure the electromagnetic brake operation circuit so that it is activated not only by the servo amplifier signals but also by an external emergency stop signal.
- The electromagnetic brake is designed to hold a load. Do not use it for braking.

The characteristics of the electromagnetic brake provided for the servo motor with electromagnetic brake are indicated below:

#### (1) Characteristics

Though the brake lining may rattle during operation, it poses no functional problem.

A leakage magnetic flux will occur at the shaft end of the servo motor equipped with electromagnetic brake.

If braking sound occurs, it may be improved by setting the machine resonance suppression filter or adaptive vibration suppression control in the servo amplifier parameters. For details, refer to the servo amplifier instruction manual.

Table 6.1 Electromagnetic Brake Characteristics

Servo Motor		HC-MF Series HC-MFS Series			HA-FF Series			
		053B · 13B	23B · 43B	73B	053B · 13B	23B · 33B	43B · 63B	
(Note 1)	Type	Spring-loaded safety brake						
(Note 4)	Rated voltage	24V <sup>0</sup> <sub>-30%</sub> DC						
Capacity	[W]	6.3	7.9	9	7	7.4	11	
Static friction torque	[N · m]	0.32	1.3	2.4	0.39	1.18	2.3	
	[oz · in]	45.3	184.2	340	55.3	167	326	
(Note 2)	Release delay time [s]	0.03	0.03	0.03	0.03	0.03	0.03	
Braking delay time [s] (Note 2)	DC off	0.01	0.02	0.03	0.01	0.03	0.03	
Permissible braking work	Per braking	[J]	5.6	22.0	64.0	3.9	18.0	46.0
		[oz · in]	793.6	3117.6	9069.3	552.7	2550.7	6518.6
	Per hour	[J]	56	220	640	39	180	460
		[oz · in]	7936	31176	90693	5527	25507	65186
Brake looseness at servo motor shaft [degrees] (Note 5)		0.19 to 2.5	0.12 to 1.2	0.1 to 0.9	0.3 to 3.5	0.2 to 2.0	0.2 to 1.3	
Brake life (Note 3)	Number of braking cycles [times]	20000	20000	20000	30000	30000	30000	
	Work per braking	[J]	4	15	32	4	18	47
		[oz · in]	567	2126	4535	567	2551	6660



## 6. CHARACTERISTICS

(Note 5) Servo Motor		HC-SF Series HC-SFS Series		HC-RF Series HC-RFS Series		HC-KF Series HC-KFS Series			HC-AQ Series	
		81B 52B to 152B 53B to 153B	121B to 301B 202B to 702B 203B · 353B	103B to 203B	353B · 503B	053B 13B	23B · 43B	(Note 6) 73B	0135B to 0335B	
Item		Spring-loaded safety brake								
(Note 1) Type		Spring-loaded safety brake								
(Note 4) Rated voltage		24V <sup>0</sup> <sub>-10%</sub> DC								
Capacity	[W]	19	34	19	23	6.3	7.9	9	4.8	
Static friction torque	[N · m]	8.3	43.1	6.8	16.7	0.32	1.3	2.4	0.098	
	[oz · in]	1176	6103	964	2367	45	6108	340	13.878	
(Note 2) Release delay time	[s]	0.04	0.1	0.03	0.04	0.03	0.1	0.03	0.02	
Braking delay time [s] (Note 2)	DC off	0.03	0.03	0.03	0.03	0.01	0.03	0.03	0.01	
Permissible braking work	Per braking	[J]	400	4500	400	400	5.6	22.0	64.0	4.6
		[oz · in]	56683.3	637687.1	56683.3	56683.3	793.6	3117.6	9069.3	63.882
	Per hour	[J]	4000	45000	4000	4000	56	220	640	46
	[oz · in]	566833	6376871	566833	566833	7936	31176	90693	638.821	
Brake looseness at servo motor shaft (Note 5)	[degrees]	0.2 to 0.6	0.2 to 0.6	0.2 to 0.6	0.2 to 0.6	0.19 to 2.5	0.12 to 1.2	0.1 to 0.9	0.1 to 2.5	
Brake life (Note 3)	Number of braking cycles [times]	20000	20000	20000	20000	20000	20000	20000	20000	
	Work per braking	[J]	200	1000	200	200	4	15	32	1
		[oz · in]	28342	141708	28342	28342	567	2124.18	4535	141.612

(Note 5) Servo Motor		HC-UF Series HC-UFS Series					HC-LFS Series		
		13B	23B · 43B	73B	72B · 152B	202B to 502B	52B to 152B	202B to 302B	
Item		Spring-loaded safety brake							
(Note 1) Type		Spring-loaded safety brake							
(Note 4) Rated voltage		24V <sup>0</sup> <sub>-10%</sub> DC							
Capacity	[W]	6.3	7.9	10	19	34	19	34	
Static friction torque	[N · m]	0.32	1.3	2.4	8.3	43.1	8.3	43.1	
	[oz · in]	45	184	340	1175	6103	1175	6103	
(Note 2) Release delay time	[s]	0.03	0.03	0.03	0.04	0.1	0.04	0.1	
Braking delay time [s] (Note 2)	DC off	0.01	0.02	0.03	0.03	0.03	0.03	0.03	
Permissible braking work	Per braking	[J]	5.6	22	64	400	4500	400	4500
		[oz · in]	793.6	3117.6	9069.3	56683.3	637687.1	56683.3	637687.1
	Per hour	[J]	56	220	640	4000	45000	4000	45000
	[oz · in]	7936	31176	90693	566833	6376871	566833	6376871	
Brake looseness at servo motor shaft (Note 5)	[degrees]	0.19 to 2.5	0.12 to 1.2	0.1 to 0.9	0.2 to 0.6	0.2 to 0.6	0.2 to 0.6	0.2 to 0.6	
Brake life (Note 3)	Number of braking cycles [times]	20000	20000	20000	20000	20000	20000	20000	
	Work per braking	[J]	4	15	32	200	1000	200	1000
		[oz · in]	567	2126	4535	28342	141708	28342	141708

- Note: 1. There is no manual release mechanism. When it is necessary to hand-turn the servo motor shaft for machine centering, etc., use a separate 24VDC power supply to release the brake electrically.
2. The value for initial ON gap at 20°C.
3. The brake gap will increase as the brake lining wears, but the gap is not adjustable. The brake life indicated is the number of braking cycles after which adjustment will be required.
4. 24VDC of the internal power output for interface (VDD) cannot be used. Always use a separate power supply.
5. The above values are typical initial values and not guaranteed values.
6. 73B is not available for the HC-KF.

## 6. CHARACTERISTICS

### (2) Electromagnetic brake power supply

24VDC of the internal power output for interface (VDD) cannot be used. Prepare the following power supply for use with the electromagnetic brake only. Examples of connection of the brake exciting power supply are shown in the following diagram. The surge absorber must be installed on the brake terminal. For the selection of the surge absorber, refer to OPTIONS AND AUXILIARY EQUIPMENT of the Servo Amplifier Instruction Manual.

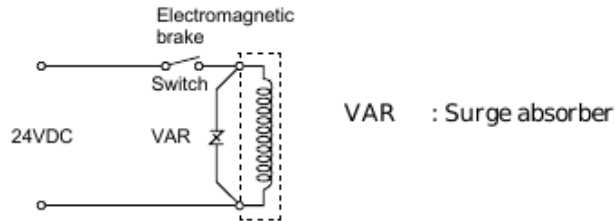

### (3) Coasting distance

At an emergency stop, the servo motor will decelerate to a stop in the pattern shown in the following diagram. Here, the maximum coasting distance (during fast feed),  $L_{max}$ , will be the area shown with the diagonal line in the figure and can be calculated approximately with Equation 6.1. The effect of the load torque is greater near the stopping area. When the load torque is large, the servo motor will stop faster than the value obtained in the equation.

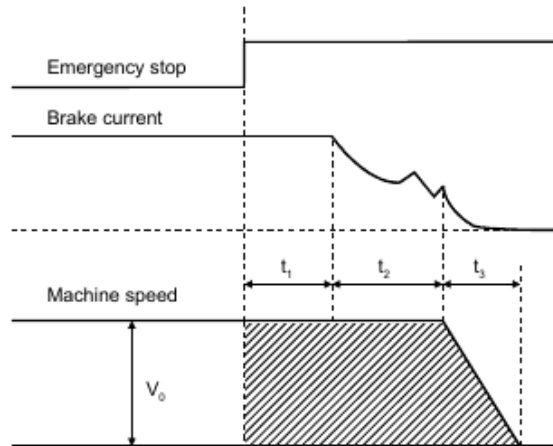

## 6. CHARACTERISTICS

$$L \text{ max} = \frac{V_0}{60} \cdot \left( t_1 + t_2 + \frac{t_3}{2} \right) \dots\dots\dots (6.1)$$

Where,

L max :	Maximum coasting distance	[mm]
V <sub>0</sub> :	Machine's fast feed speed	[mm/min]
t <sub>1</sub> :	Delay time of control section	[s]
t <sub>2</sub> :	Braking delay time of brake (Note)	[s]
t <sub>3</sub> :	Braking time	[s]
$t_3 = \frac{(J_L + J_M) \cdot N_0}{9.55 \times 10^4 \cdot (T_L + 0.8T_B)}$		
J <sub>L</sub> :	Load inertia moment converted into equivalent value on servo motor shaft	[kg · cm <sup>2</sup> ]
J <sub>M</sub> :	Servo motor inertia moment	[kg · cm <sup>2</sup> ]
N <sub>0</sub> :	Servomotor speed during fast feed	[r/min]
T <sub>L</sub> :	Load torque converted into equivalent value on servo motor shaft	[N · m]
T <sub>B</sub> :	Brake static friction torque (Note)	[N · m]

Note: t<sub>2</sub> and T<sub>B</sub> are the values noted in Table 6.1 Characteristics. J<sub>L</sub> is the machine's inertia moment at the servo motor shaft.

### 6.2 Vibration rank

The vibration rank of the servo motor is V-10 at the rated speed. Measure vibration in the following position with the servo motor installed as shown below.

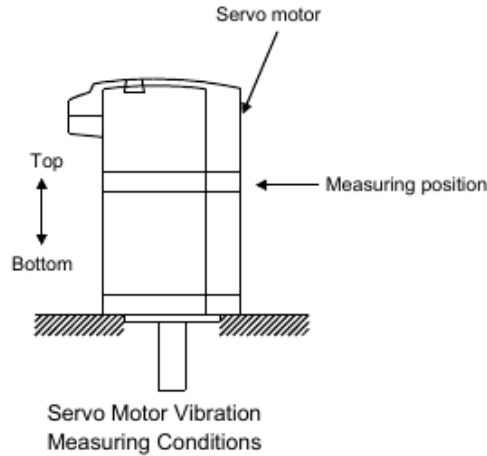

## 6. CHARACTERISTICS

### 6.3 Machine Accuracies

The following table indicates the machine accuracies of the servo motor around the output shaft and mounting.

Accuracy TIR (Total Indicator Reading) [mm]	Measuring Position	Flange Size			
		Less than □100	□100 · □130	□176 to □250	□280 or more
Squareness of flange surface to output shaft	a)	0.05	0.06	0.08	0.08
Eccentricity of fitting OD of flange surface	b)	0.04	0.04	0.06	0.08
Runout of output shaft end	c)	0.02	0.02	0.03	0.03

Reference diagram

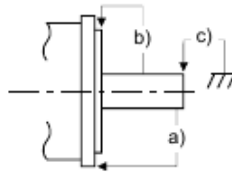

# MEMO

---

---

---

---

---

---

---

---

---

---

---

---

---

---

---

---

---

---

---

---

---

---

---

---

---

## 7. OUTLINE DIMENTION DRAWING

### 7. OUTLINE DIMENSION DRAWINGS

#### 7.1 Servo motors

##### 7.1.1 HC-MF · HC-KF series

##### (1) Standard (without electromagnetic brake, without reduction gear)

Model	Output [W]	Variable Dimensions		Inertia Moment $J[\times 10^{-4} \text{kg} \cdot \text{m}^2]$	Weight [kg]
		L	KL		
HC-MF 053	50	81.5	29.5	0.019	0.40
HC-MF 13	100	96.5	44.5	0.03	0.53
HC-KF 053	50	81.5	29.5	0.053	0.40
HC-KF 13	100	96.5	44.5	0.084	0.53

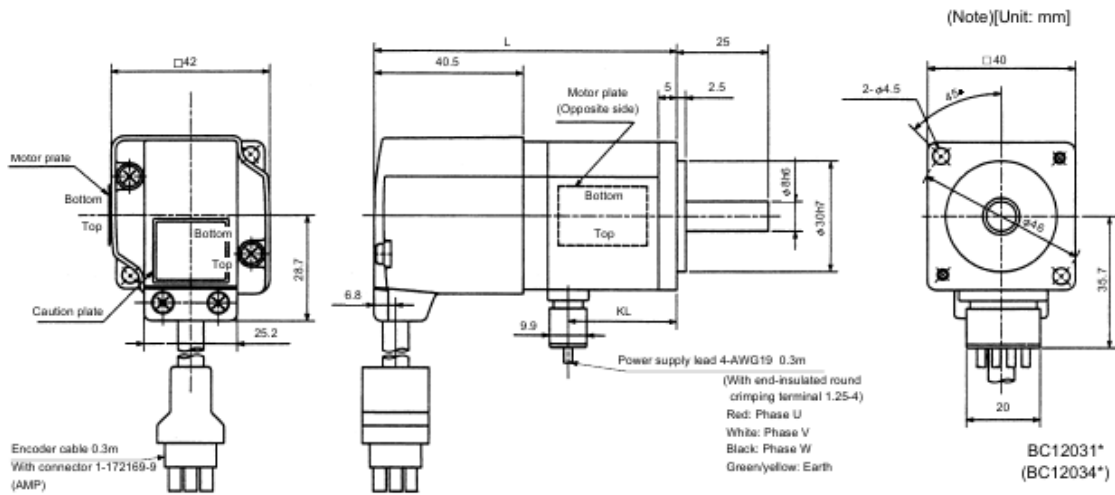

Note: The dimensions without tolerances are reference dimensions.

Model	Output [W]	Variable Dimensions		Inertia Moment $J[\times 10^{-4} \text{kg} \cdot \text{m}^2]$	Weight [kg]
		L	KL		
HC-MF 23	200	99.5	49.1	0.088	0.99
HC-MF 43	400	124.5	72.1	0.143	1.45
HC-KF 23	200	99.5	49.1	0.42	0.99
HC-KF 43	400	124.5	72.1	0.67	1.45

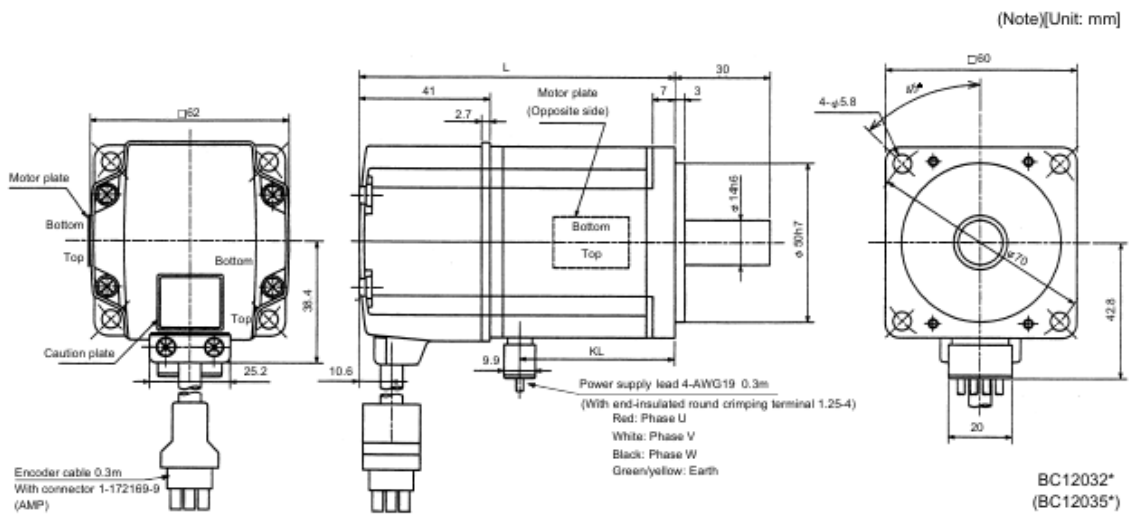

Note: The dimensions without tolerances are reference dimensions.

## 7. OUTLINE DIMENSION DRAWING

Model	Output [W]	Inertia Moment $J[\times 10^{-4} \text{kg} \cdot \text{m}^2]$	Weight [kg]
HC-MF73	750	0.6	3

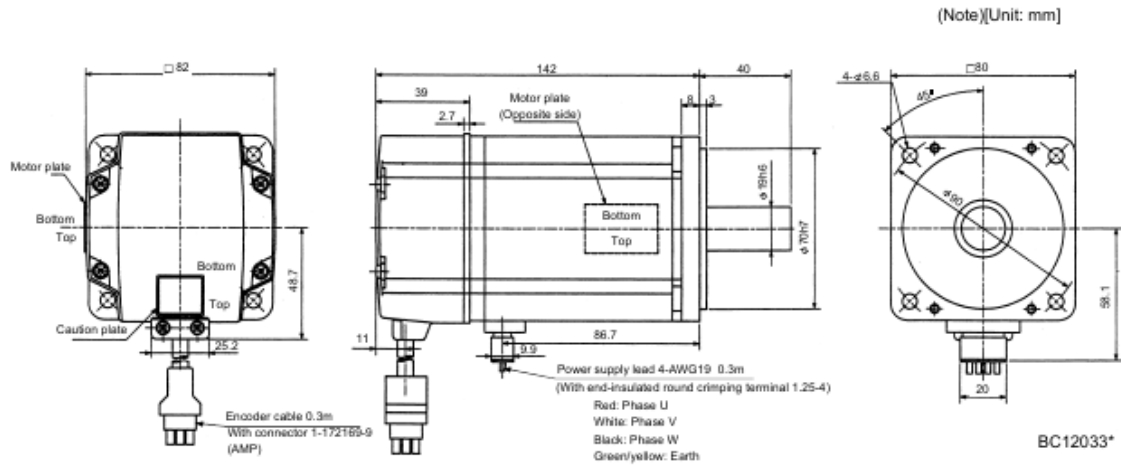

Note: The dimensions without tolerances are reference dimensions.

### (2) With electromagnetic brake

Model	Output [W]	Variable Dimensions		Braking Force [N · m]	Inertia Moment $J[\times 10^{-4} \text{kg} \cdot \text{m}^2]$	Weight [kg]
		L	KL			
HC-MF053B	50	109.5	29.5	0.32	0.022	0.75
HC-MF13B	100	124.5	44.5	0.32	0.032	0.89
HC-KF053B	50	109.5	29.5	0.32	0.056	0.75
HC-KF13B	100	124.5	44.5	0.32	0.087	0.89

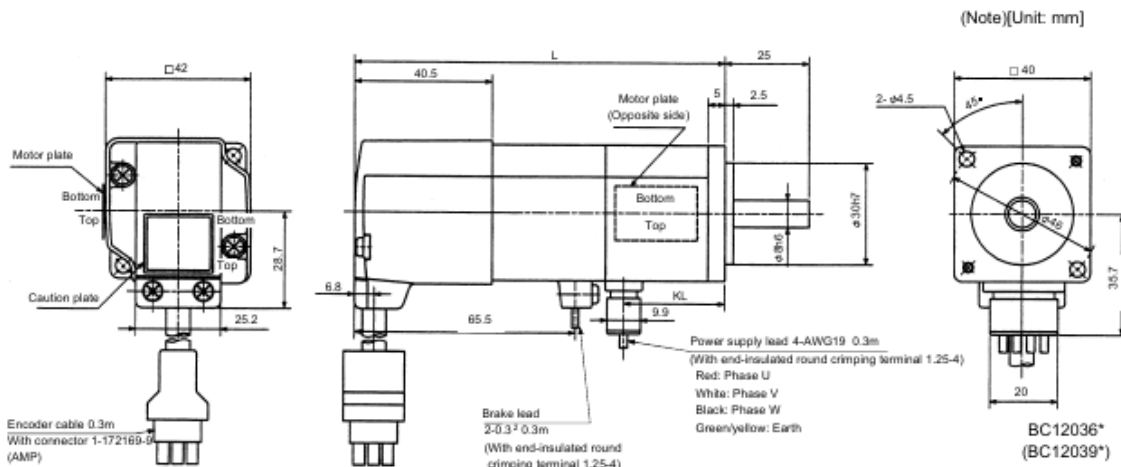

Note: The dimensions without tolerances are reference dimensions.

## 7. OUTLINE DIMENSION DRAWING

Model	Output [W]	Variable Dimensions		Braking Force [N · m]	Inertia Moment J [ $\times 10^{-4}$ kg · m <sup>2</sup> ]	Weight [kg]
		L	KL			
HC-MF23B	200	131.5	49.1	1.3	0.136	1.6
HC-MF43B	400	156.5	72.1	1.3	0.191	2.1
HC-KF23B	200	131.5	49.1	1.3	0.47	1.6
HC-KF43B	400	156.5	72.1	1.3	0.72	2.1

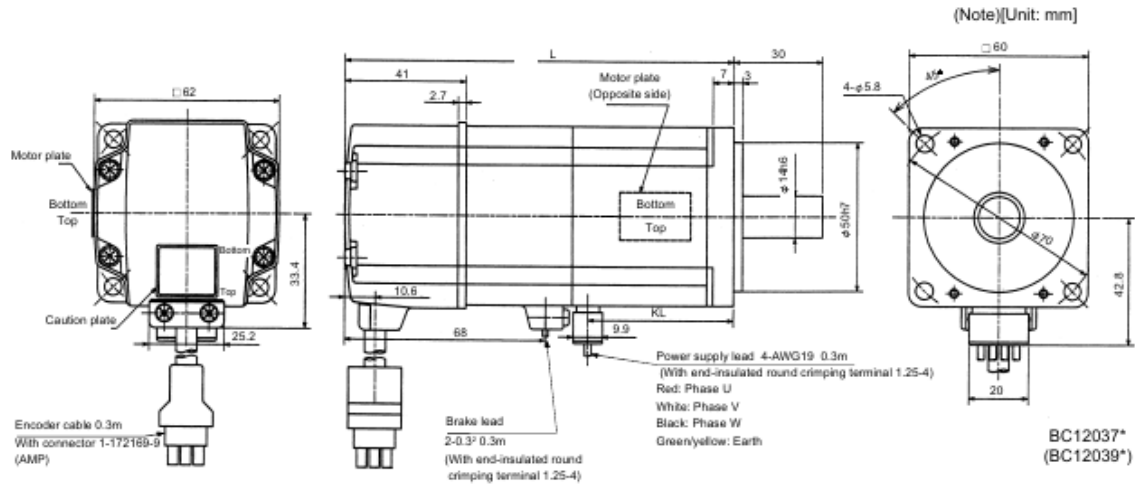

Note: The dimensions without tolerances are reference dimensions.

Model	Output [W]	Braking Force [N · m]	Inertia Moment J [ $\times 10^{-4}$ kg · m <sup>2</sup> ]	Weight [kg]
HC-MF73B	750	2.4	0.725	4.0

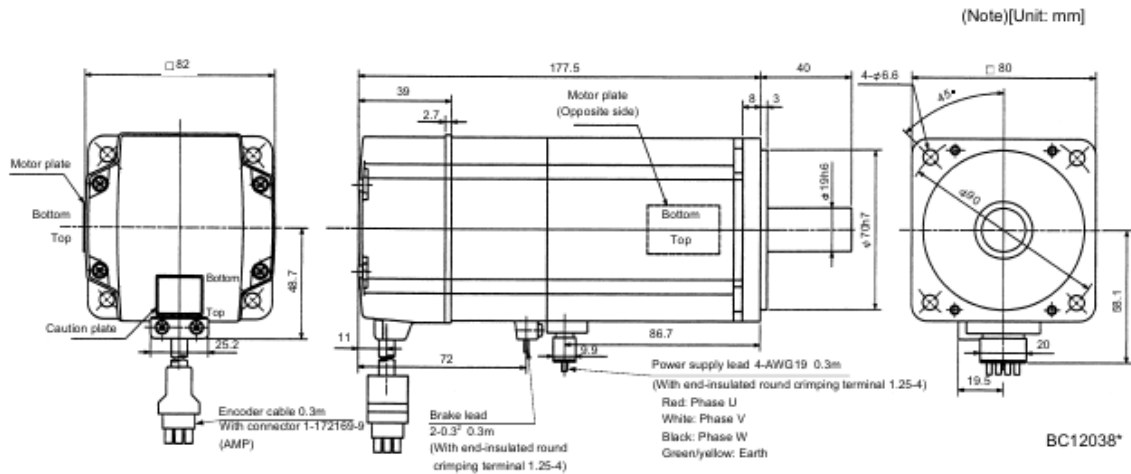

Note: The dimensions without tolerances are reference dimensions.



## 7. OUTLINE DIMENSION DRAWING

### (3) With reduction gear for general industrial machine

The outer frame of the reduction gear is a material surface such as casting. Its actual dimensions may be 1 to 3mm larger than the drawing dimensions. Design the machine side with allowances.

#### (a) Without electromagnetic brake

Model	Output [W]	Variable Dimensions		Reduction Gear Model	Reduction Ratio (Actual Reduction Ratio)	Inertia Moment $J[\times 10^{-4} \text{kg} \cdot \text{m}^2]$	Backlash	Weight [kg]
		L	KL					
HC-MF053G1	50	126	74	K 6505	1/5(9/44)	0.055	60min. max.	1.4
HC-MF053G1	50	144	92	K 6512	1/12(49/576)	0.077	60min. max.	1.8
HC-MF053G1	50	144	92	K 6520	1/20(25/484)	0.059	60min. max.	1.8
HC-KF053G1	50	126	74	K 6505	1/5(9/44)	0.090	60min. max.	1.4
HC-KF053G1	50	144	92	K 6512	1/12(49/576)	0.112	60min. max.	1.8
HC-KF053G1	50	144	92	K 6520	1/20(25/484)	0.094	60min. max.	1.8

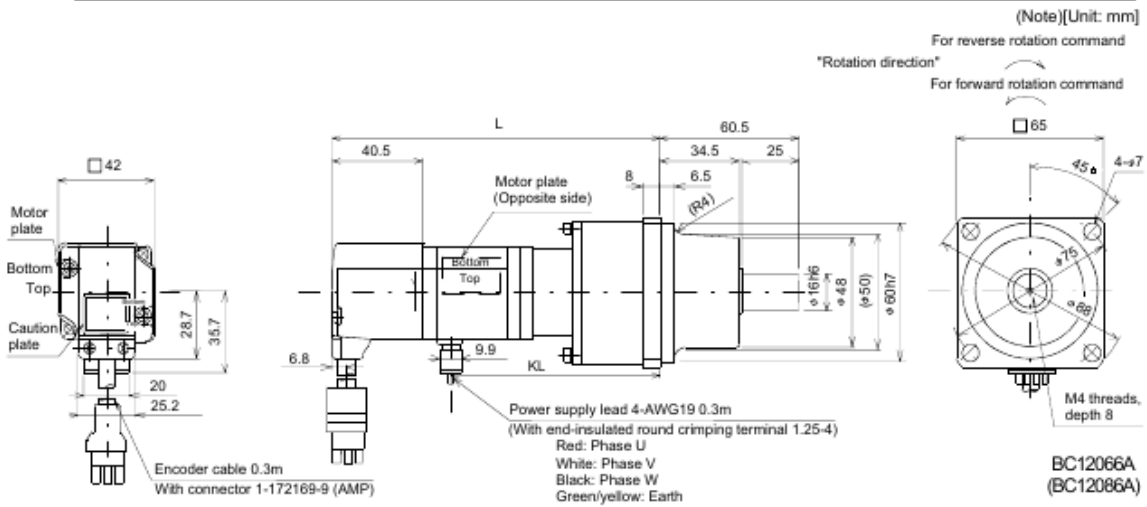

Note: The dimensions without tolerances are reference dimensions.

Model	Output [W]	Variable Dimensions		Reduction Gear Model	Reduction Ratio (Actual Reduction Ratio)	Inertia Moment $J[\times 10^{-4} \text{kg} \cdot \text{m}^2]$	Backlash	Weight [kg]
		L	KL					
HC-MF13G1	100	141	89	K 6505	1/5(9/44)	0.067	60min. max.	1.5
HC-MF13G1	100	159	107	K 6512	1/12(49/576)	0.089	60min. max.	1.9
HC-MF13G1	100	159	107	K 6520	1/20(25/484)	0.071	60min. max.	1.9
HC-KF13G1	100	141	89	K 6505	1/5(9/44)	0.121	60min. max.	1.5
HC-KF13G1	100	159	107	K 6512	1/12(49/576)	0.143	60min. max.	1.9
HC-KF13G1	100	159	107	K 6520	1/20(25/484)	0.125	60min. max.	1.9

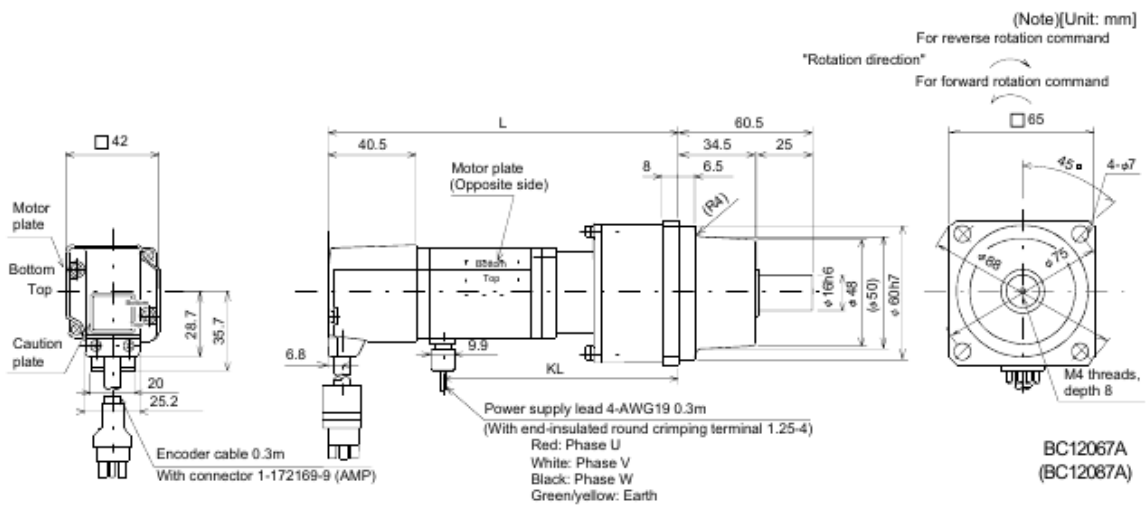

Note: The dimensions without tolerances are reference dimensions.

## 7. OUTLINE DIMENSION DRAWING

Model	Output [W]	Variable Dimensions		Reduction Gear Model	Reduction Ratio (Actual Reduction Ratio)	Inertia Moment $J[\times 10^{-4} \text{kg} \cdot \text{m}^2]$	Weight [kg]
		L	KL				
HC-MF23G1	200	153	102.6	K 9005	1/5(19/96)	0.249	3.3
HC-MF23G1	200	173	122.6	K 9012	1/12(25/288)	0.293	3.9
HC-MF23G1	200	173	122.6	K 9020	1/20(253/5000)	0.266	3.9
HC-KF23G1	200	153	102.6	K 9005	1/5(19/96)	0.58	3.3
HC-KF23G1	200	173	122.6	K 9012	1/12(25/288)	0.63	3.9
HC-KF23G1	200	173	122.6	K 9020	1/20(253/5000)	0.60	3.9

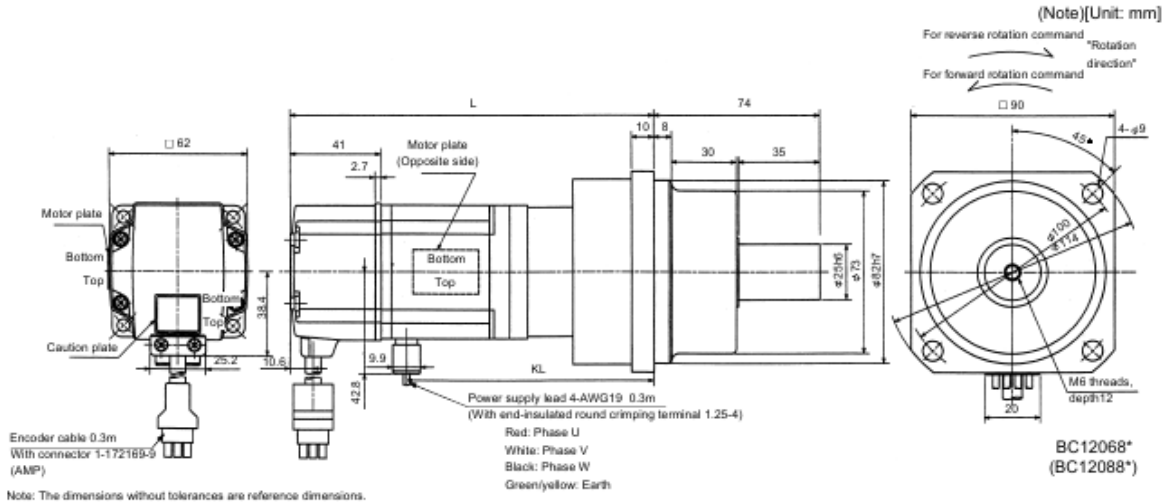

Model	Output [W]	Variable Dimensions		Reduction Gear Model	Reduction Ratio (Actual Reduction Ratio)	Inertia Moment $J[\times 10^{-4} \text{kg} \cdot \text{m}^2]$	Weight [kg]
		L	KL				
HC-MF43G1	400	178	125.6	K 9005	1/5(19/96)	0.296	3.8
HC-MF43G1	400	198	145.6	K 9012	1/12(25/288)	0.339	4.4
HC-KF43G1	400	178	125.6	K 9005	1/5(19/96)	0.82	3.8
HC-KF43G1	400	198	145.6	K 9012	1/12(25/288)	0.87	4.4

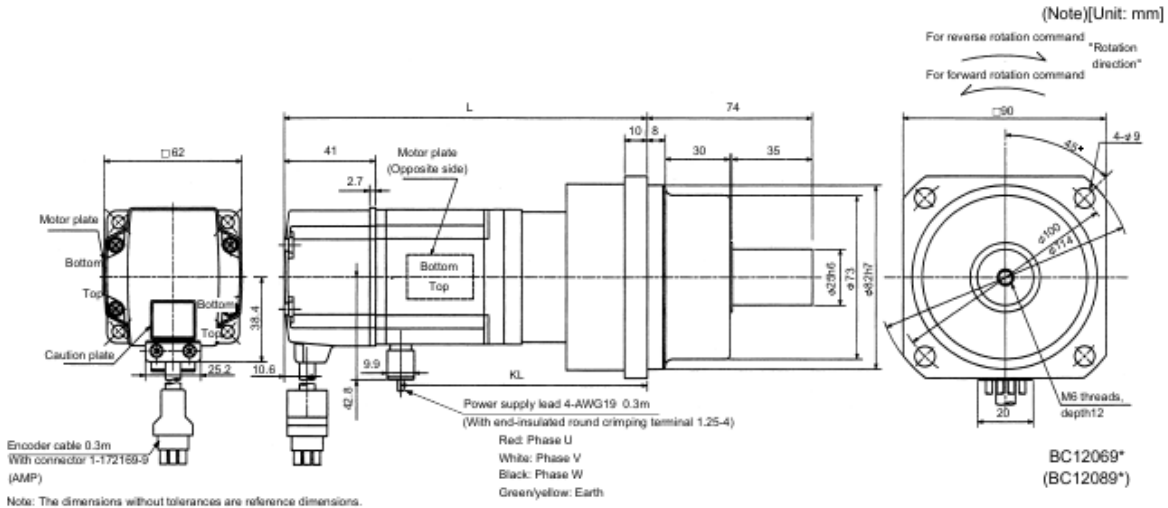

## 7. OUTLINE DIMENSION DRAWING

Model	Output [W]	Reduction Gear Model	Reduction Ratio		Inertia Moment $J[\times 10^{-4} \text{kg} \cdot \text{m}^2]$	Backlash	Weight [kg]
			Normal Reduction ratio	Actual Reduction Ratio			
HC-MF43G1	400	K10020	1/20	253/5000	0.653	60min. max.	5.5
HC-MF73G1	750	K10005	1/5	1/5	1.02	60min. max.	6.2
HC-MF73G1	750	K10012	1/12	525/6048	1.686	60min. max.	7.3
HC-MF73G1	750	K12020	1/20	625/12544	1.75	60min. max.	10.1

Model	Output [W]	Variable Dimensions																						
		D	LH	LK	LT	H	LA	LB	LC	LD	LE	LF	LG	LM	LN	LP	L	LR	KL	LZ	Q	S	P	R
HC-MF43G1	400	62	38.4	41	10.6	42.8	115	95	132	100	10	73	10	13	16	86	201.5	90	149.1	9	50	32	M8	16
HC-MF73G1	750	82	48.7	39	11	58.1	115	95	132	100	10	73	10	13	16	86	207	90	151.7	9	50	32	M8	16
HC-MF73G1	750	82	48.7	39	11	58.1	115	95	132	100	10	73	10	13	16	86	229	90	173.7	9	50	32	M8	16
HC-MF73G1	750	82	48.7	39	11	58.1	140	115	162	120	12	90	15	13	20	104	242	106	186.7	14	60	40	M10	20

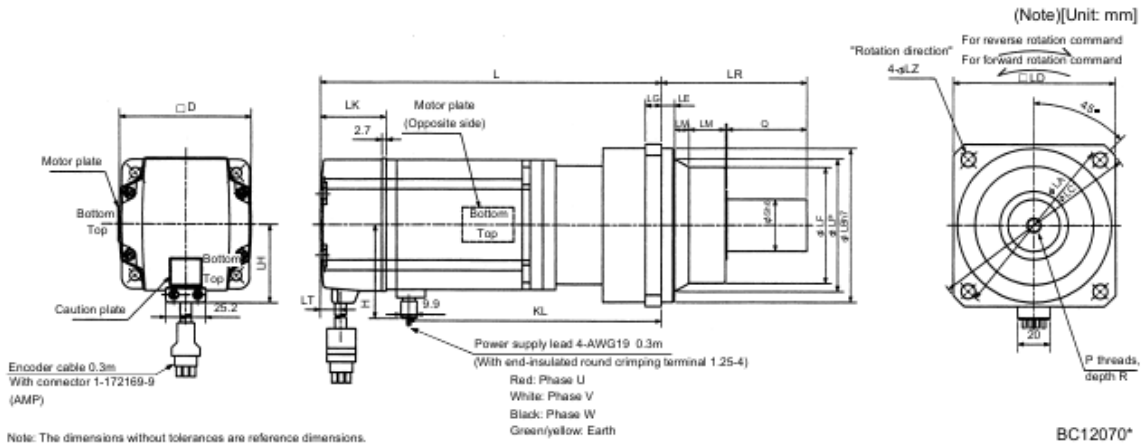

Model	Output [W]	Reduction Gear Model	Reduction Ratio		Inertia Moment $J[\times 10^{-4} \text{kg} \cdot \text{m}^2]$	Backlash	Weight [kg]
			Normal Reduction ratio	Actual Reduction Ratio			
HC-KF43G1	400	K10020	1/20	253/5000	1.18	60min. max.	5.5

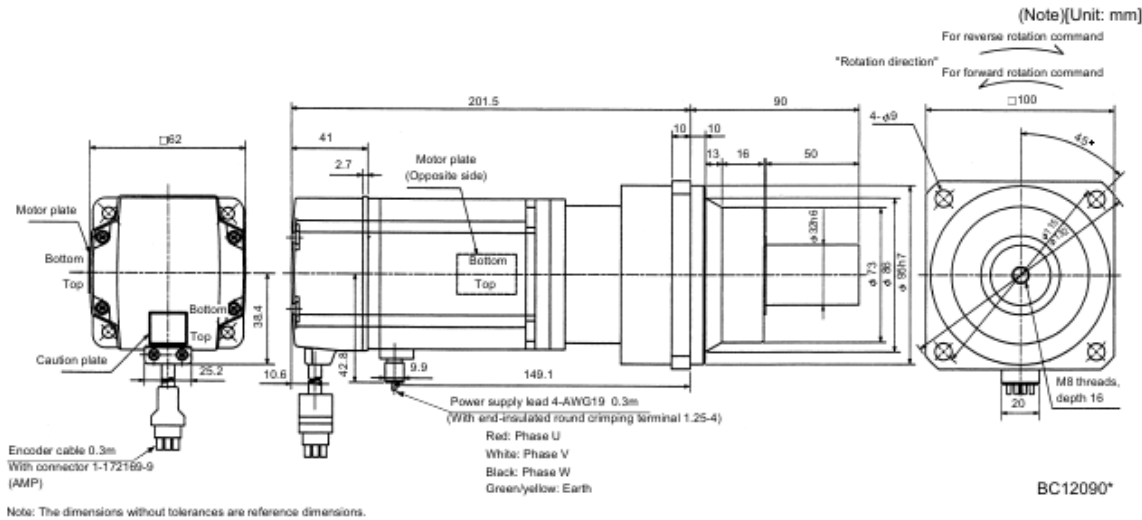

## 7. OUTLINE DIMENSION DRAWING

### (b) With electromagnetic brake

Model	Output [W]	Variable Dimensions		Braking Force [N · m]	Reduction Gear Model	Reduction Ratio (Actual Reduction Ratio)	Inertia Moment J [ $\times 10^{-4}$ kg · m <sup>2</sup> ]	Backlash	Weight [kg]
		L	KL						
HC-MF053BG1	50	154	74	0.32	K 6505	1/5(9/44)	0.058	60min. max.	1.8
HC-MF053BG1	50	172	92	0.32	K 6512	1/12(49/576)	0.080	60min. max.	2.2
HC-MF053BG1	50	172	92	0.32	K 6520	1/20(25/484)	0.062	60min. max.	2.2
HC-KF053BG1	50	154	74	0.32	K 6505	1/5(9/44)	0.093	60min. max.	1.8
HC-KF053BG1	50	172	92	0.32	K 6512	1/12(49/576)	0.115	60min. max.	2.2
HC-KF053BG1	50	172	92	0.32	K 6520	1/20(25/484)	0.097	60min. max.	2.2

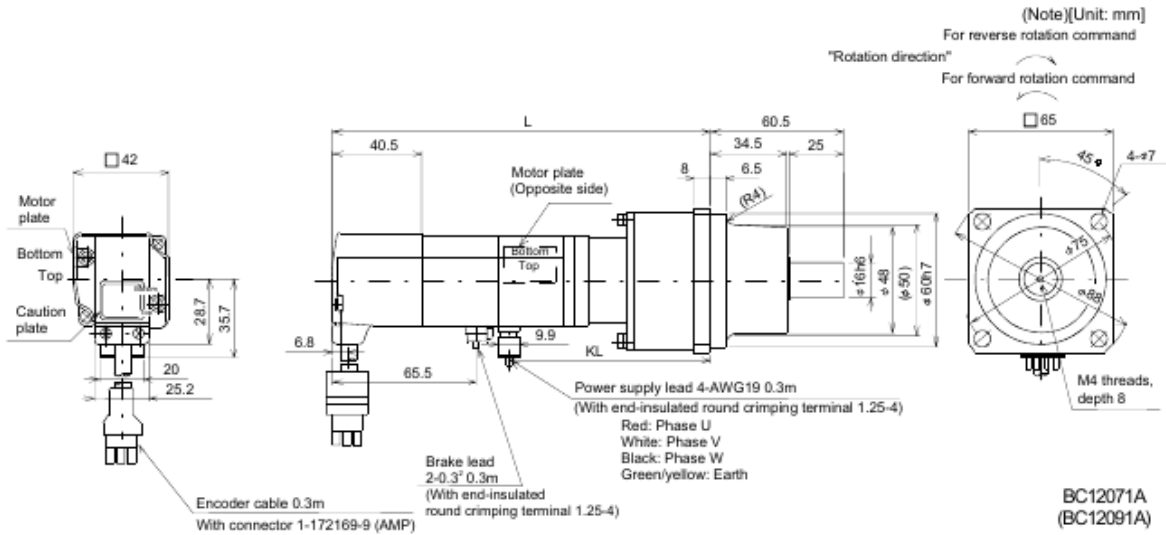

Note: The dimensions without tolerances are reference dimensions.

Model	Output [W]	Variable Dimensions		Braking Force [N · m]	Reduction Gear Model	Reduction Ratio (Actual Reduction Ratio)	Inertia Moment J [ $\times 10^{-4}$ kg · m <sup>2</sup> ]	Backlash	Weight [kg]
		L	KL						
HC-MF13BG1	100	169	89	0.32	K 6505	1/5(9/44)	0.069	60min. max.	1.9
HC-MF13BG1	100	187	107	0.32	K 6512	1/12(49/576)	0.091	60min. max.	2.3
HC-MF13BG1	100	187	107	0.32	K 6520	1/20(25/484)	0.073	60min. max.	2.3
HC-KF13BG1	100	169	89	0.32	K 6505	1/5(9/44)	0.124	60min. max.	1.9
HC-KF13BG1	100	187	107	0.32	K 6512	1/12(49/576)	0.146	60min. max.	2.3
HC-KF13BG1	100	187	107	0.32	K 6520	1/20(25/484)	0.128	60min. max.	2.3

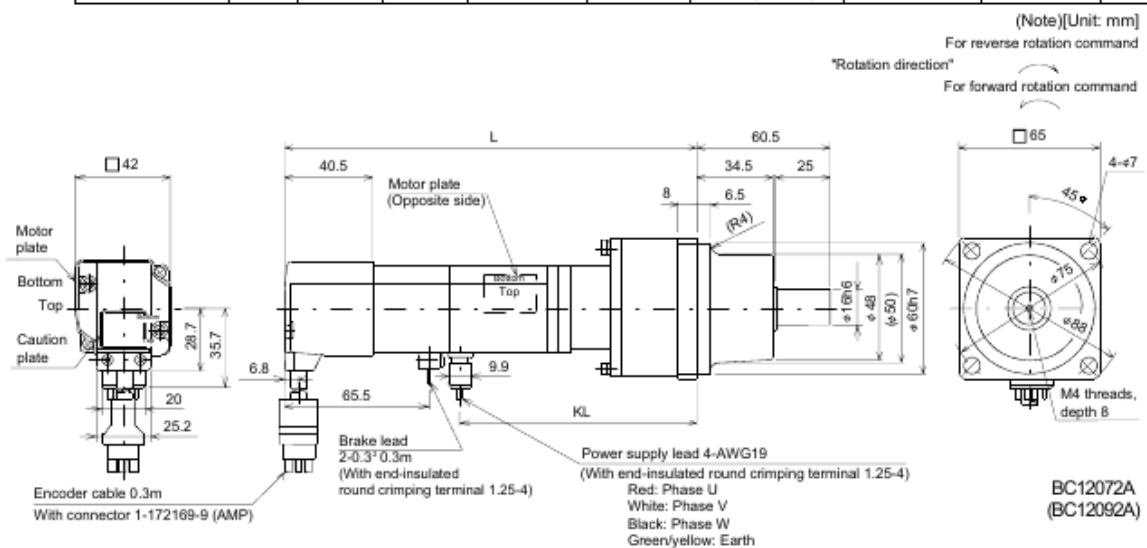

Note: The dimensions without tolerances are reference dimensions.

## 7. OUTLINE DIMENSION DRAWING

Model	Output [W]	Variable Dimensions		Reduction Gear Model	Reduction Ratio (Actual Reduction Ratio)	Inertia Moment $J[\times 10^{-4} \text{kg} \cdot \text{m}^2]$	Weight [kg]	Braking Force [N · m]
		L	KL					
HC-MF23BG1	200	185	102.6	K9005	1/5(19/96)	0.289	3.9	1.3
HC-MF23BG1	200	205	122.6	K9012	1/12(25/288)	0.333	4.5	1.3
HC-MF23BG1	200	205	122.6	K9020	1/20(253/5000)	0.306	4.5	1.3
HC-KF23BG1	200	185	102.6	K9005	1/5(19/96)	0.63	3.9	1.3
HC-KF23BG1	200	205	122.6	K9012	1/12(25/288)	0.68	4.5	1.3
HC-KF23BG1	200	205	122.6	K9020	1/20(253/5000)	0.65	4.5	1.3

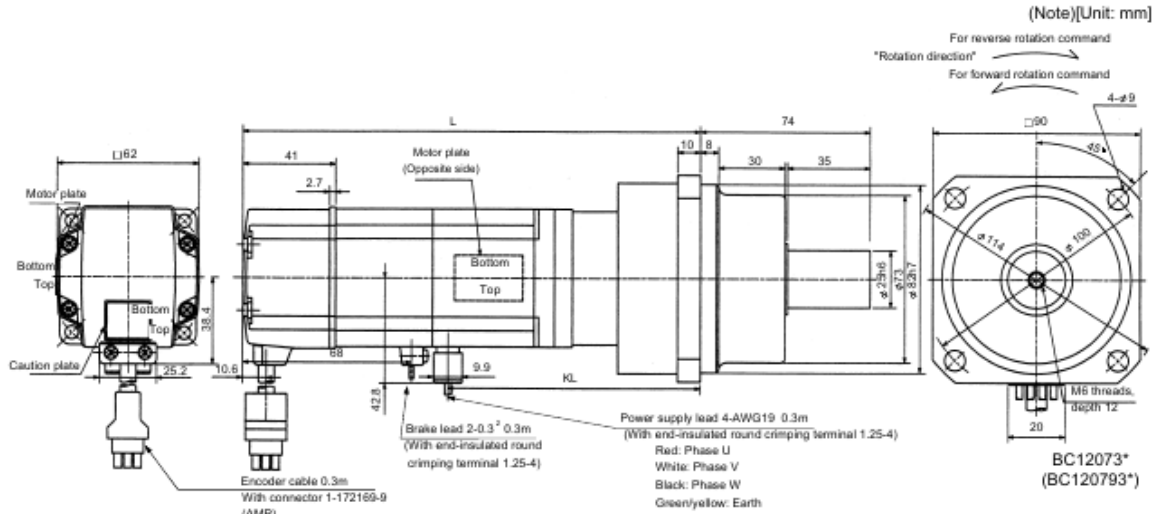

Note: The dimensions without tolerances are reference dimensions.

Model	Output [W]	Variable Dimensions		Braking Force [N · m]	Reduction Gear Model	Reduction Ratio (Actual Reduction Ratio)	Inertia Moment $J[\times 10^{-4} \text{kg} \cdot \text{m}^2]$	Weight [kg]
		L	KL					
HC-MF43BG1	400	210	125.6	1.3	K9005	1/5(19/96)	0.344	4.4
HC-MF43BG1	400	230	145.6	1.3	K9012	1/12(25/288)	0.388	5.0
HC-KF43BG1	400	210	125.6	1.3	K9005	1/5(19/96)	0.87	4.4
HC-KF43BG1	400	230	145.6	1.3	K9012	1/12(25/288)	0.92	5.0

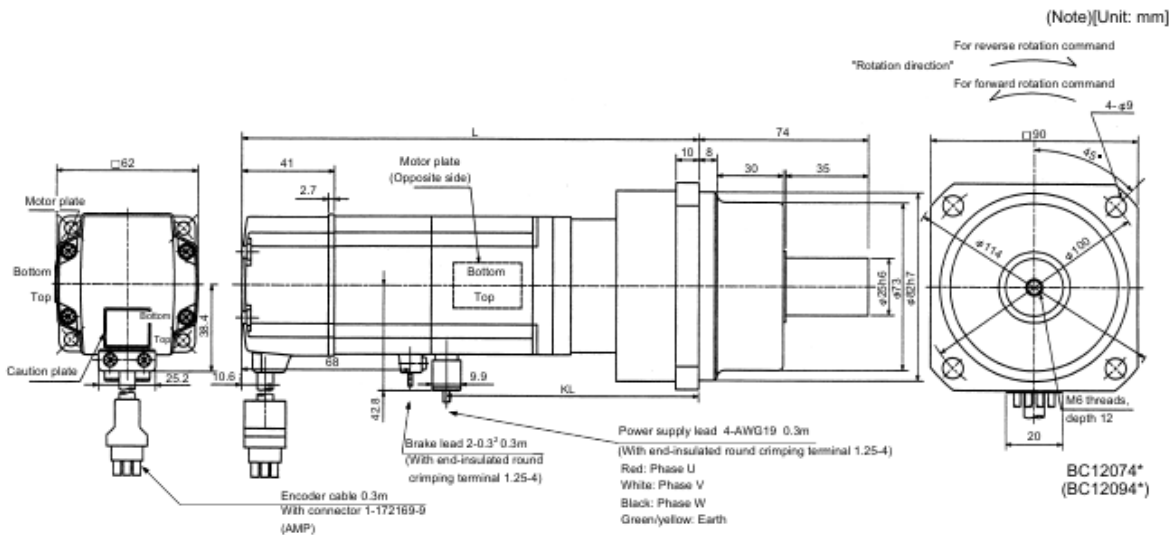

Note: The dimensions without tolerances are reference dimensions.

## 7. OUTLINE DIMENSION DRAWING

Model	Output [W]	Braking Force [N · m]	Reduction Gear Model	Reduction Ratio		Inertia Moment J [ $\times 10^{-4}$ kg · m <sup>2</sup> ]	Backlash	Weight [kg]
				Normal Reduction ratio	Actual Reduction Ratio			
HC-MF43BG1	400	1.3	K10020	1/20	253/5000	0.700	60min. max.	6.1
HC-MF73BG1	750	2.4	K10005	1/5	1/5	1.145	60min. max.	7.2
HC-MF73BG1	750	2.4	K10012	1/12	525/6048	1.811	60min. max.	8.3
HC-MF73BG1	750	2.4	K12020	1/20	625/12544	1.875	60min. max.	11.1

Model	Output [W]	Variable Dimensions																							
		D	LH	LK	LT	LX	H	LA	LB	LC	LD	LE	LF	LG	LM	LN	LP	L	LR	KL	LZ	Q	S	P	R
HC-MF43BG1	400	62	38.4	41	10.6	68	42.8	115	95	132	100	10	73	10	13	16	86	232.5	90	149.1	9	50	32	M8	16
HC-MF73BG1	750	82	48.7	39	11	72	58.1	115	95	132	100	10	73	10	13	16	86	242.5	90	151.7	9	50	32	M8	16
HC-MF73BG1	750	82	48.7	39	11	72	58.1	115	95	132	100	10	73	10	13	16	86	264.5	90	173.7	9	50	32	M8	16
HC-MF73BG1	750	82	48.7	39	11	72	58.1	140	115	162	120	12	90	15	13	20	104	277.5	106	186.7	14	60	40	M10	20

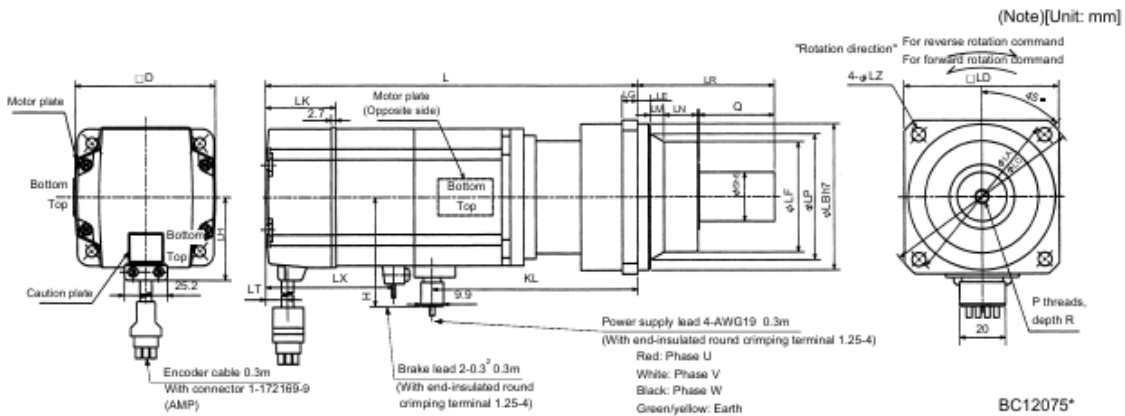

Note: The dimensions without tolerances are reference dimensions.

Model	Output [W]	Braking Force [N · m]	Reduction Gear Model	Reduction Ratio		Inertia Moment J [ $\times 10^{-4}$ kg · m <sup>2</sup> ]	Backlash	Weight [kg]
				Normal Reduction ratio	Actual Reduction Ratio			
HC-KF43BG1	400	1.3	K10020	1/20	253/5000	1.23	60min. max.	6.1

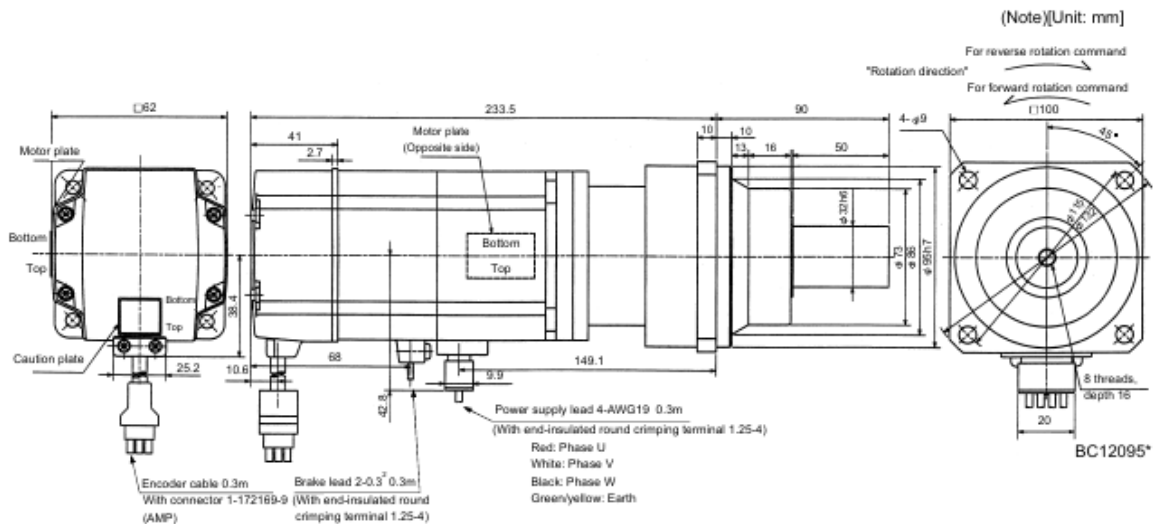

Note: The dimensions without tolerances are reference dimensions.

## 7. OUTLINE DIMENSION DRAWING

### (4) With reduction gear for precision application

The outer frame of the reduction gear is a material surface such as casting. Its actual dimensions may be 1 to 3mm larger than the drawing dimensions. Design the machine side with allowances.

#### (a) Without electromagnetic brake

Model	Output [W]	Variable Dimensions		Reduction Gear Model	Reduction Ratio	Inertia Moment $J[\times 10^{-4} \text{kg} \cdot \text{m}^2]$	Backlash	Weight [kg]
		L	KL					
HC-MF053G2	50	130	78	BK 1-05B-A5MEKA	1/5	0.067	3 min. max.	1.4
HC-MF053G2	50	146	94	BK 1-09B-A5MEKA	1/9	0.060	3 min. max.	1.7
HC-MF053G2	50	146	94	BK 1-20B-A5MEKA	1/20	0.069	3 min. max.	1.8
HC-MF053G2	50	146	94	BK 1-29B-A5MEKA	1/29	0.057	3 min. max.	1.8
HC-KF053G2	50	130	78	BK 1-05B-A5MEKA	1/5	0.101	3 min. max.	1.4
HC-KF053G2	50	146	94	BK 1-09B-A5MEKA	1/9	0.095	3 min. max.	1.7
HC-KF053G2	50	146	94	BK 1-20B-A5MEKA	1/20	0.104	3 min. max.	1.8
HC-KF053G2	50	146	94	BK 1-29B-A5MEKA	1/29	0.092	3 min. max.	1.8

(Note)[Unit: mm]

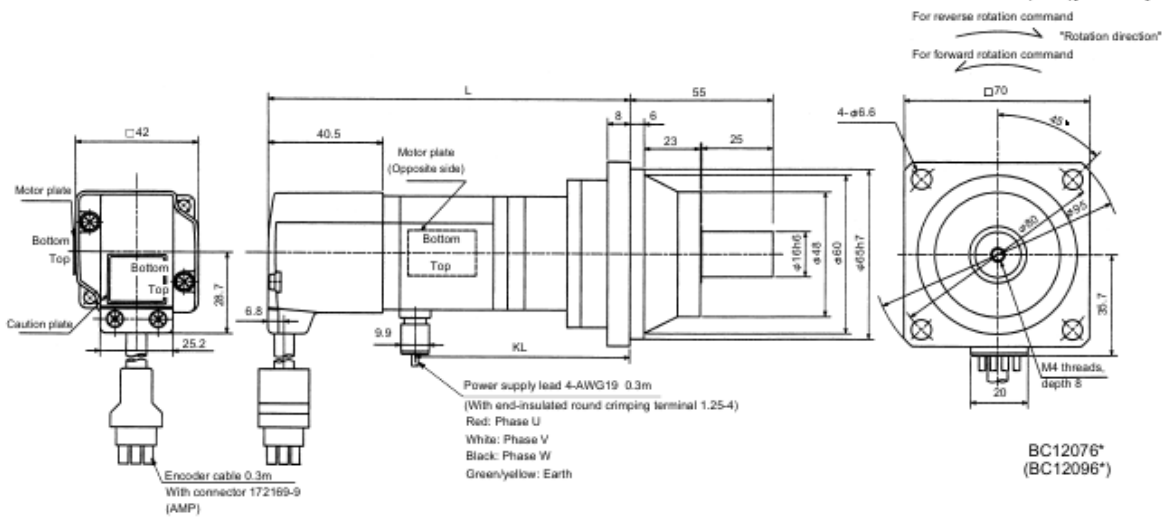

Note: The dimensions without tolerances are reference dimensions.

## 7. OUTLINE DIMENSION DRAWING

Model	Output [W]	Reduction Gear Model	Reduction Ratio	Inertia Moment $J[\times 10^{-4} \text{kg} \cdot \text{m}^2]$	Backlash	Weight [kg]
HC-MF13G2	100	BK1-05B-01MEKA	1/5	0.078	3 min. max.	1.5
HC-MF13G2	100	BK1-09B-01MEKA	1/9	0.072	3 min. max.	1.8
HC-MF13G2	100	BK1-20B-01MEKA	1/20	0.122	3 min. max.	3.0
HC-MF13G2	100	BK1-29B-01MEKA	1/29	0.096	3 min. max.	3.0

Model	Output [W]	Variable Dimensions																
		LA	LB	LC	LD	LE	LF	LG	LH	LK	L	LR	KL	LZ	Q	S	P	R
HC-MF13G2	100	80	65	95	70	6	48	8	60	23	145	55	93	6.6	25	16	M4	8
HC-MF13G2	100	80	65	95	70	6	48	8	60	23	161	55	109	6.6	25	16	M4	8
HC-MF13G2	100	100	80	115	85	6	65	10	74	33	167	75	115	6.6	35	20	M5	10
HC-MF13G2	100	100	80	115	85	6	65	10	74	33	167	75	115	6.6	35	20	M5	10

Model	Output [W]	Reduction Gear Model	Reduction Ratio	Inertia Moment $J[\times 10^{-4} \text{kg} \cdot \text{m}^2]$	Backlash	Weight [kg]
HC-KF13G2	100	BK1-05B-01MEKA	1/5	0.132	3 min. max.	1.5
HC-KF13G2	100	BK1-09B-01MEKA	1/9	0.126	3 min. max.	1.8
HC-KF13G2	100	BK2-20B-01MEKA	1/20	0.176	3 min. max.	3.0
HC-KF13G2	100	BK2-29B-01MEKA	1/29	0.150	3 min. max.	3.0

Model	Output [W]	Variable Dimensions																
		LA	LB	LC	LD	LE	LF	LG	LH	LK	L	LR	KL	LZ	Q	S	P	R
HC-KF13G2	100	80	65	95	70	6	48	8	60	23	145	55	93	6.6	25	16	M4	8
HC-KF13G2	100	80	65	95	70	6	48	8	60	23	161	55	109	6.6	25	16	M4	8
HC-KF13G2	100	100	80	115	85	6	65	10	74	33	167	75	115	6.6	35	20	M5	10
HC-KF13G2	100	100	80	115	85	6	65	10	74	33	167	75	115	6.6	35	20	M5	10

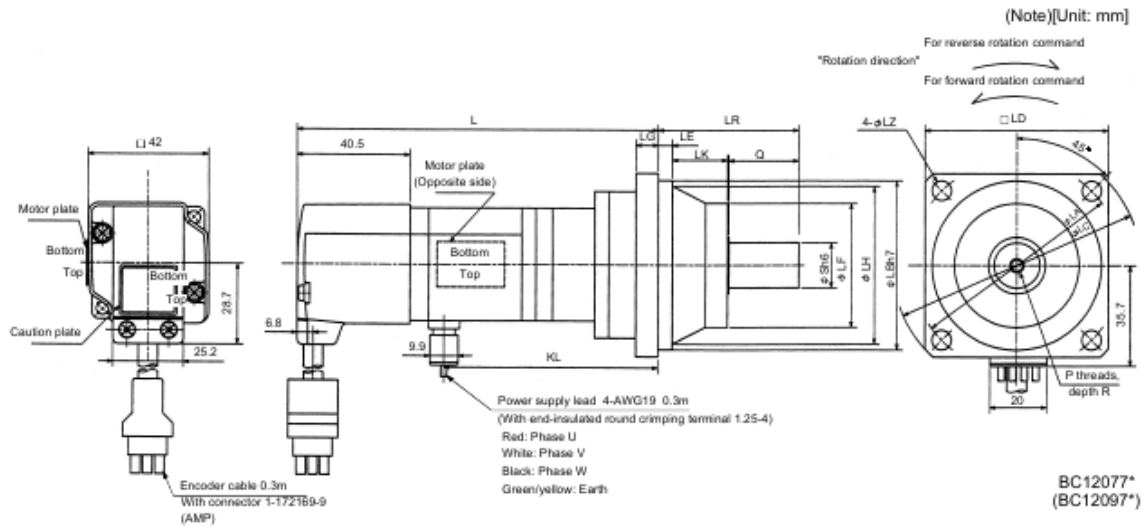

Note: The dimensions without tolerances are reference dimensions.



## 7. OUTLINE DIMENSION DRAWING

Model	Output [W]	Reduction Gear Model	Reduction Ratio	Inertia Moment $J[\times 10^{-4} \text{kg} \cdot \text{m}^2]$	Weight [kg]
HC-MF23G2	200	BK1-05B-02MEKA	1/5	0.191	2.1
HC-MF23G2	200	BK2-09B-02MEKA	1/9	0.208	3.5
HC-MF23G2	200	BK3-20B-02MEKA	1/20	0.357	5.0
HC-MF23G2	200	BK3-29B-02MEKA	1/29	0.276	5.0

Model	Output [W]	Variable Dimensions																
		LA	LB	LC	LD	LE	LF	LG	LH	LK	L	LR	KL	LZ	Q	S	P	R
HC-MF23G2	200	80	65	95	70	6	48	8	60	23	157	55	106.6	6.6	25	16	M4	8
HC-MF23G2	200	100	80	115	85	6	65	10	74	33	175	75	124.6	6.6	35	20	M5	10
HC-MF23G2	200	115	95	135	100	8	75	10	85	35	180	85	129.6	9	40	25	M6	12
HC-MF23G2	200	115	95	135	100	8	75	10	85	35	180	85	129.6	9	40	25	M6	12

Model	Output [W]	Reduction Gear Model	Reduction Ratio	Inertia Moment $J[\times 10^{-4} \text{kg} \cdot \text{m}^2]$	Weight [kg]
HC-KF23G2	200	BK1-05B-02MEKA	1/5	0.52	2.1
HC-KF23G2	200	BK2-09B-02MEKA	1/9	0.54	3.5
HC-KF23G2	200	BK3-20B-02MEKA	1/20	0.69	5.0
HC-KF23G2	200	BK3-29B-02MEKA	1/29	0.61	5.0

Model	Output [W]	Variable Dimensions																
		LA	LB	LC	LD	LE	LF	LG	LH	LK	L	LR	KL	LZ	Q	S	P	R
HC-KF23G2	200	80	65	95	70	6	48	8	60	23	157	55	106.6	6.6	25	16	M4	8
HC-KF23G2	200	100	80	115	85	6	65	10	74	33	175	75	124.6	6.6	35	20	M5	10
HC-KF23G2	200	115	95	135	100	8	75	10	85	35	180	85	129.6	9	40	25	M6	12
HC-KF23G2	200	115	95	135	100	8	75	10	85	35	180	85	129.6	9	40	25	M6	12

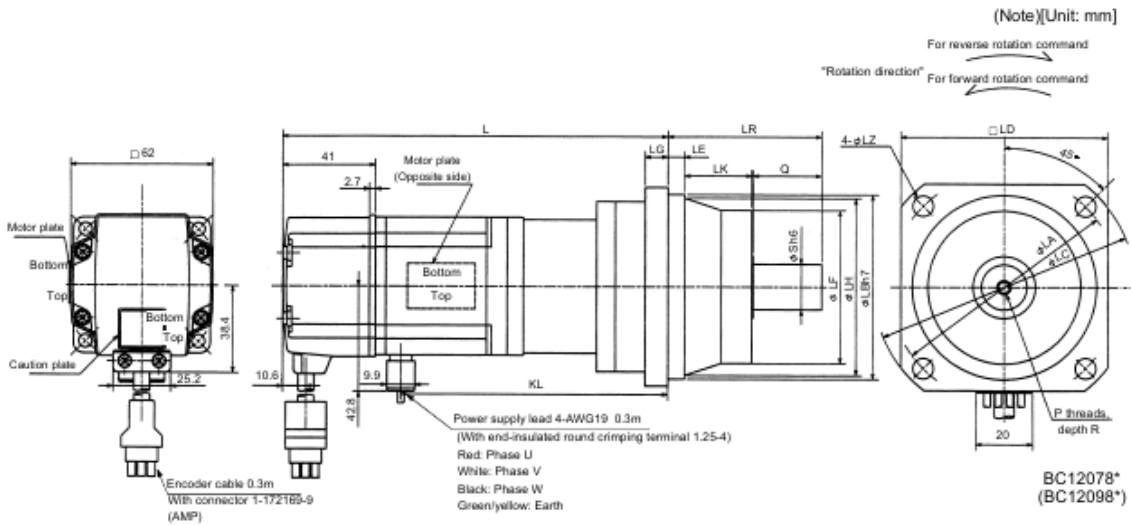

Note: The dimensions without tolerances are reference dimensions.

## 7. OUTLINE DIMENSION DRAWING

Model	Output [W]	Reduction Gear Model	Reduction Ratio	Inertia Moment $J[\times 10^{-4} \text{kg} \cdot \text{m}^2]$	Weight [kg]
HC-MF43G2	400	BK2-05B-04MEKA	1/5	0.295	3.7
HC-MF43G2	400	BK3-09B-04MEKA	1/9	0.323	5.3
HC-MF43G2	400	BK4-20B-04MEKA	1/20	0.426	7.5
HC-MF43G2	400	BK4-29B-04MEKA	1/29	0.338	7.5

Model	Output [W]	Variable Dimensions																
		LA	LB	LC	LD	LE	LF	LG	LH	LK	L	LR	KL	LZ	Q	S	P	R
HC-MF43G2	400	100	80	115	85	6	65	10	74	33	184	75	131.6	6.6	35	20	M5	10
HC-MF43G2	400	115	95	135	100	8	75	10	85	35	205	85	152.6	9	40	25	M6	12
HC-MF43G2	400	135	110	155	115	8	90	12	100	40	211	100	158.6	11	50	32	M8	16
HC-MF43G2	400	135	110	155	115	8	90	12	100	40	211	100	158.6	11	50	32	M8	16

Model	Output [W]	Reduction Gear Model	Reduction Ratio	Inertia Moment $J[\times 10^{-4} \text{kg} \cdot \text{m}^2]$	Weight [kg]
HC-KF43G2	400	BK2-05B-04MEKA	1/5	0.82	3.7
HC-KF43G2	400	BK3-09B-04MEKA	1/9	0.85	5.3
HC-KF43G2	400	BK4-20B-04MEKA	1/20	0.95	7.5
HC-KF43G2	400	BK4-29B-04MEKA	1/29	0.87	7.5

Model	Output [W]	Variable Dimensions																
		LA	LB	LC	LD	LE	LF	LG	LH	LK	L	LR	KL	LZ	Q	S	P	R
HC-KF43G2	400	100	80	115	85	6	65	10	74	33	184	75	131.6	6.6	35	20	M5	10
HC-KF43G2	400	115	95	135	100	8	75	10	85	35	205	85	152.6	9	40	25	M6	12
HC-KF43G2	400	135	110	155	115	8	90	12	100	40	211	100	158.6	11	50	32	M8	16
HC-KF43G2	400	135	110	155	115	8	90	12	100	40	211	100	158.6	11	50	32	M8	16

(Note)[Unit: mm]

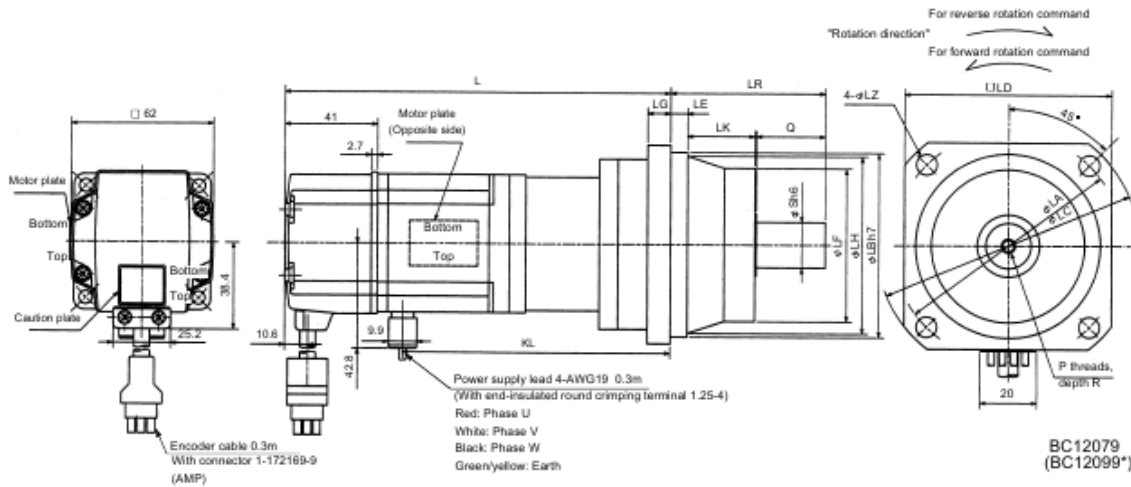

Note: The dimensions without tolerances are reference dimensions.

## 7. OUTLINE DIMENSION DRAWING

Model	Output [W]	Reduction Gear Model	Reduction Ratio	Inertia Moment $J[\times 10^{-4} \text{kg} \cdot \text{m}^2]$	Weight [kg]
HC-MF 73G2	750	BK3-05B-08MEKA	1/5	0.973	6.3
HC-MF 73G2	750	BK4-09B-08MEKA	1/9	0.980	8.6
HC-MF 73G2	750	BK5-20B-08MEKA	1/20	1.016	12.0
HC-MF 73G2	750	BK5-29B-08MEKA	1/29	0.910	12.0

Model	Output [W]	Variable Dimensions																
		LA	LB	LC	LD	LE	LF	LG	LH	LK	L	LR	KL	LZ	Q	S	P	R
HC-MF 73G2	750	115	95	135	100	8	75	10	85	35	212	85	156.7	9	40	25	M6	12
HC-MF 73G2	750	135	110	155	115	8	90	12	100	40	248	100	192.7	11	50	32	M8	16
HC-MF 73G2	750	150	125	175	130	10	105	15	115	43	248	115	192.7	14	60	40	M10	20
HC-MF 73G2	750	150	125	175	130	10	105	15	115	43	248	115	192.7	14	60	40	M10	20

(Note)[Unit: mm]

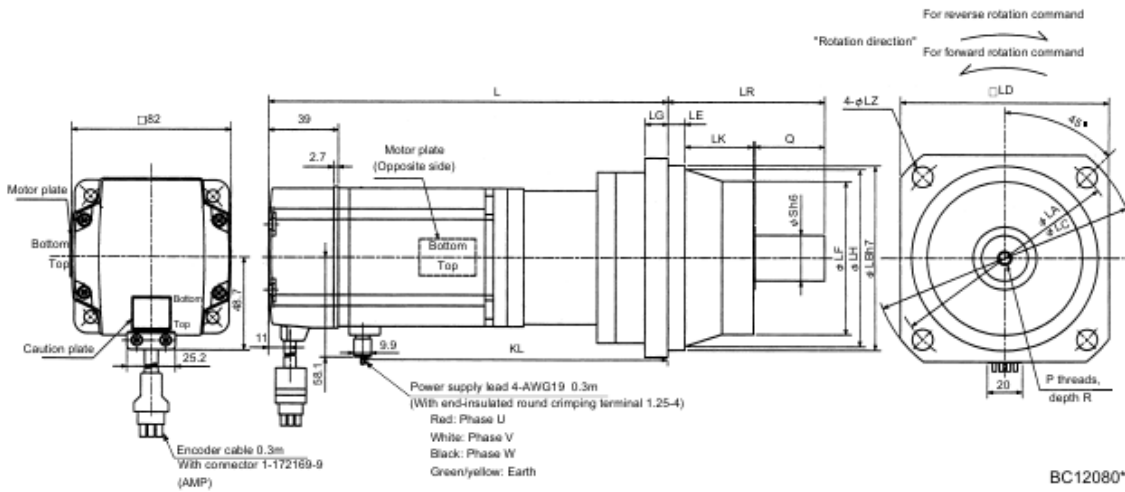

Note: The dimensions without tolerances are reference dimensions.

## 7. OUTLINE DIMENSION DRAWING

### (b) With electromagnetic brake

Model	Output [W]	Variable Dimensions		Braking Force [N · m]	Reduction Gear Model	Reduction Ratio	Inertia Moment J [ $\times 10^{-4}$ kg · m <sup>2</sup> ]	Backlash	Weight [kg]
		L	KL						
HC-MF053G2	50	158	78	0.32	BK1-05B-A5MEKA	1/5	0.070	3 min. max.	1.8
HC-MF053G2	50	174	94	0.32	BK1-09B-A5MEKA	1/9	0.063	3 min. max.	2.1
HC-MF053G2	50	174	94	0.32	BK1-20B-A5MEKA	1/20	0.072	3 min. max.	2.2
HC-MF053G2	50	174	94	0.32	BK1-29B-A5MEKA	1/29	0.060	3 min. max.	2.2
HC-KF053G2	50	158	78	0.32	BK1-05B-A5MEKA	1/5	0.104	3 min. max.	1.8
HC-KF053G2	50	174	94	0.32	BK1-09B-A5MEKA	1/9	0.098	3 min. max.	2.1
HC-KF053G2	50	174	94	0.32	BK1-20B-A5MEKA	1/20	0.107	3 min. max.	2.2
HC-KF053G2	50	174	94	0.32	BK1-29B-A5MEKA	1/29	0.095	3 min. max.	2.2

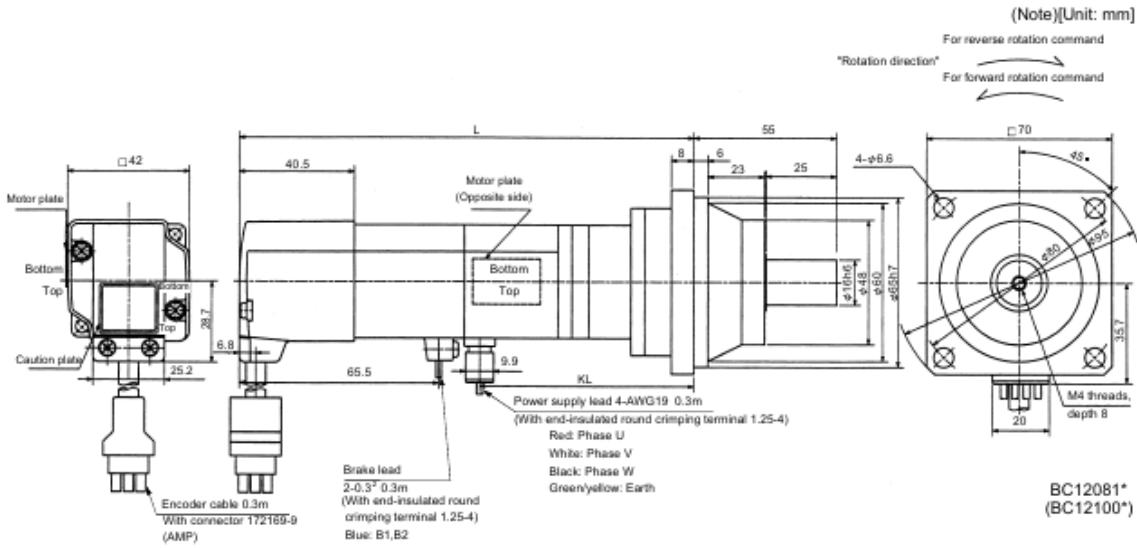

Note: The dimensions without tolerances are reference dimensions.

## 7. OUTLINE DIMENSION DRAWING

Model	Output [W]	Braking Force [N · m]	Reduction Gear Model	Reduction Ratio	Inertia Moment J [ $\times 10^{-4}$ kg · m <sup>2</sup> ]	Backlash	Weight [kg]
HC-MF13BG2	100	0.32	BK1-05B-01MEKA	1/5	0.080	3 min. max.	1.9
HC-MF13BG2	100	0.32	BK1-09B-01MEKA	1/9	0.074	3 min. max.	2.2
HC-MF13BG2	100	0.32	BK2-20B-01MEKA	1/20	0.124	3 min. max.	3.4
HC-MF13BG2	100	0.32	BK2-29B-01MEKA	1/29	0.098	3 min. max.	3.4

Model	Output [W]	Variable Dimensions																
		LA	LB	LC	LD	LE	LF	LG	LH	LK	L	LR	KL	LZ	Q	S	P	R
HC-MF13BG2	100	80	65	95	70	6	48	8	60	23	173	55	93	6.6	25	16	M4	8
HC-MF13BG2	100	80	65	95	70	6	48	8	60	23	189	55	109	6.6	25	16	M4	8
HC-MF13BG2	100	100	80	115	85	6	65	10	74	33	195	75	115	6.6	35	20	M5	10
HC-MF13BG2	100	100	80	115	85	6	65	10	74	33	195	75	115	6.6	35	20	M5	10

Model	Output [W]	Braking Force [N · m]	Reduction Gear Model	Reduction Ratio	Inertia Moment J [ $\times 10^{-4}$ kg · m <sup>2</sup> ]	Backlash	Weight [kg]
HC-KF13BG2	100	0.32	BK1-05B-01MEKA	1/5	0.135	3 min. max.	1.9
HC-KF13BG2	100	0.32	BK1-09B-01MEKA	1/9	0.129	3 min. max.	2.2
HC-KF13BG2	100	0.32	BK2-20B-01MEKA	1/20	0.179	3 min. max.	3.4
HC-KF13BG2	100	0.32	BK2-29B-01MEKA	1/29	0.153	3 min. max.	3.4

Model	Output [W]	Variable Dimensions																
		LA	LB	LC	LD	LE	LF	LG	LH	LK	L	LR	KL	LZ	Q	S	P	R
HC-KF13BG2	100	80	65	95	70	6	48	8	60	23	173	55	93	6.6	25	16	M4	8
HC-KF13BG2	100	80	65	95	70	6	48	8	60	23	189	55	109	6.6	25	16	M4	8
HC-KF13BG2	100	100	80	115	85	6	65	10	74	33	195	75	115	6.6	35	20	M5	10
HC-KF13BG2	100	100	80	115	85	6	65	10	74	33	195	75	115	6.6	35	20	M5	10

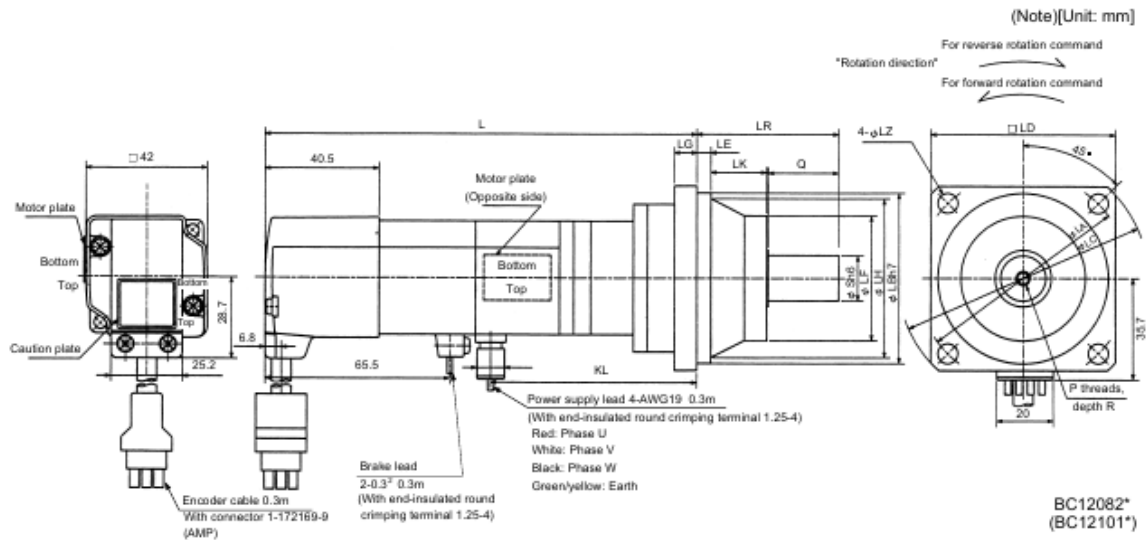

Note: The dimensions without tolerances are reference dimensions.

## 7. OUTLINE DIMENSION DRAWING

Model	Output [W]	Braking Force [N · m]	Reduction Gear Model	Reduction Ratio	Inertia Moment J [ $\times 10^{-4}$ kg · m <sup>2</sup> ]	Weight [kg]
HC-MF23BG2	200	1.3	BK1-05B-02MEKA	1/5	0.239	2.7
HC-MF23BG2	200	1.3	BK2-09B-02MEKA	1/9	0.256	4.1
HC-MF23BG2	200	1.3	BK3-20B-02MEKA	1/20	0.405	5.6
HC-MF23BG2	200	1.3	BK3-29B-02MEKA	1/29	0.324	5.6

Model	Output [W]	Variable Dimensions																
		LA	LB	LC	LD	LE	LF	LG	LH	LK	L	LR	KL	LZ	Q	S	P	R
HC-MF23BG2	200	80	65	95	70	6	48	8	60	23	189	55	106.6	6.6	25	16	M4	8
HC-MF23BG2	200	100	80	115	85	6	65	10	74	33	207	75	124.6	6.6	35	20	M5	10
HC-MF23BG2	200	115	95	135	100	8	75	10	85	35	212	85	129.6	9	40	25	M6	12
HC-MF23BG2	200	115	95	135	100	8	75	10	85	35	212	85	129.6	9	40	25	M6	12

Model	Output [W]	Braking Force [N · m]	Reduction Gear Model	Reduction Ratio	Inertia Moment J [ $\times 10^{-4}$ kg · m <sup>2</sup> ]	Weight [kg]
HC-KF23BG2	200	1.3	BK1-05B-01MEKA	1/5	0.57	2.7
HC-KF23BG2	200	1.3	BK2-09B-01MEKA	1/9	0.59	4.1
HC-KF23BG2	200	1.3	BK3-20B-01MEKA	1/20	0.74	5.6
HC-KF23BG2	200	1.3	BK3-29B-01MEKA	1/29	0.66	5.6

Model	Output [W]	Variable Dimensions																
		LA	LB	LC	LD	LE	LF	LG	LH	LK	L	LR	KL	LZ	Q	S	P	R
HC-KF23BG2	200	80	65	95	70	6	48	8	60	23	189	55	106.6	6.6	25	16	M4	8
HC-KF23BG2	200	100	80	115	85	6	65	10	74	33	207	75	124.6	6.6	35	20	M5	10
HC-KF23BG2	200	115	95	135	100	8	75	10	85	35	212	85	129.6	9	40	25	M6	12
HC-KF23BG2	200	115	95	135	100	8	75	10	85	35	212	85	129.6	9	40	25	M6	12

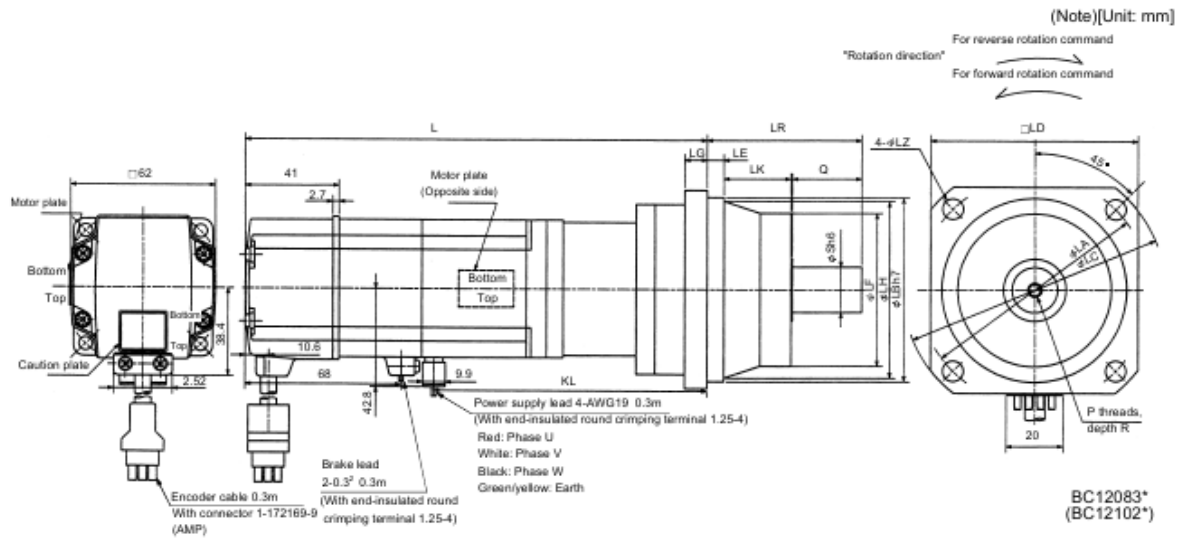

Note: The dimensions without tolerances are reference dimensions.

## 7. OUTLINE DIMENSION DRAWING

Model	Output [W]	Braking Force [N · m]	Reduction Gear Model	Reduction Ratio	Inertia Moment J [ $\times 10^{-4}$ kg · m <sup>2</sup> ]	Weight [kg]
HC-MF43BG2	400	1.3	BK2-05B-04MEKA	1/5	0.344	4.3
HC-MF43BG2	400	1.3	BK3-09B-04MEKA	1/9	0.372	5.9
HC-MF43BG2	400	1.3	BK4-20B-04MEKA	1/20	0.475	8.1
HC-MF43BG2	400	1.3	BK4-29B-04MEKA	1/29	0.386	8.1

Model	Output [W]	Variable Dimensions																
		LA	LB	LC	LD	LE	LF	LG	LH	LK	L	LR	KL	LZ	Q	S	P	R
HC-MF43BG2	400	100	80	115	85	6	65	10	74	33	216	75	131.6	6.6	35	20	M5	10
HC-MF43BG2	400	115	95	135	100	8	75	10	85	35	237	85	152.6	9	40	25	M6	12
HC-MF43BG2	400	135	110	155	115	8	90	12	100	40	243	100	158.6	11	50	32	M8	16
HC-MF43BG2	400	135	110	155	115	8	90	12	100	40	243	100	158.6	11	50	32	M8	16

Model	Output [W]	Braking Force [N · m]	Reduction Gear Model	Reduction Ratio	Inertia Moment J [ $\times 10^{-4}$ kg · m <sup>2</sup> ]	Weight [kg]
HC-KF43BG2	400	1.3	BK2-05B-04MEKA	1/5	0.87	4.3
HC-KF43BG2	400	1.3	BK3-09B-04MEKA	1/9	0.90	5.9
HC-KF43BG2	400	1.3	BK4-20B-04MEKA	1/20	1.00	8.1
HC-KF43BG2	400	1.3	BK4-29B-04MEKA	1/29	0.92	8.1

Model	Output [W]	Variable Dimensions																
		LA	LB	LC	LD	LE	LF	LG	LH	LK	L	LR	KL	LZ	Q	S	P	R
HC-MF43BG2	400	100	80	115	85	6	65	10	74	33	216	75	131.6	6.6	35	20	M5	10
HC-MF43BG2	400	115	95	135	100	8	75	10	85	35	237	85	152.6	9	40	25	M6	12
HC-MF43BG2	400	135	110	155	115	8	90	12	100	40	243	100	158.6	11	50	32	M8	16
HC-MF43BG2	400	135	110	155	115	8	90	12	100	40	243	100	158.6	11	50	32	M8	16

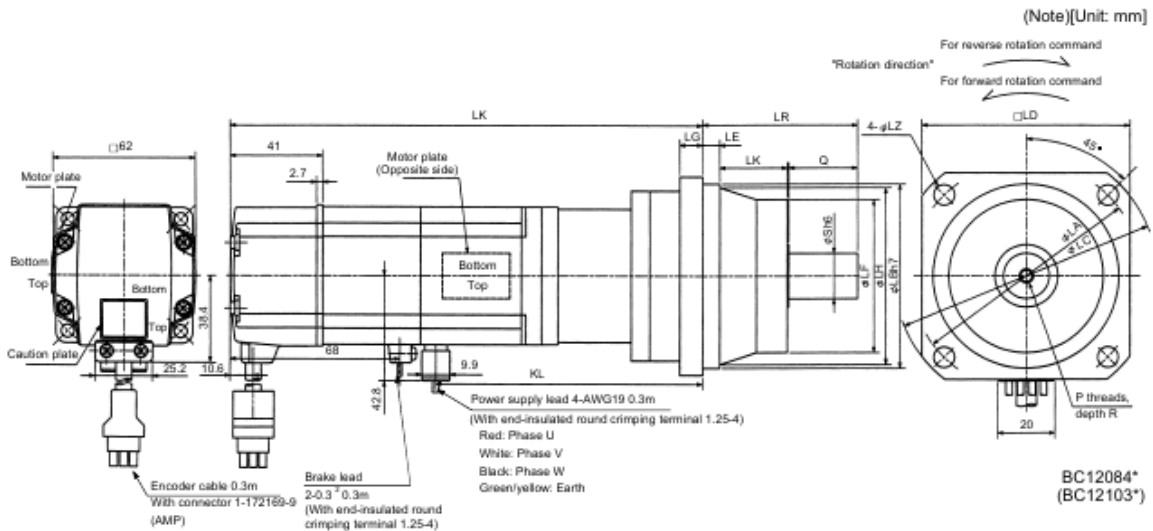

Note: The dimensions without tolerances are reference dimensions.

## 7. OUTLINE DIMENSION DRAWING

Model	Output [W]	Braking Force [N · m]	Reduction Gear Model	Reduction Ratio	Inertia Moment J [ $\times 10^{-4}$ kg · m <sup>2</sup> ]	Weight [kg]
HC-MF 73BG2	750	2.4	BK 3-05B-08MEKA	1/5	1.098	7.3
HC-MF 73BG2	750	2.4	BK 4-09B-08MEKA	1/9	1.105	9.6
HC-MF 73BG2	750	2.4	BK 5-20B-08MEKA	1/20	1.141	13.0
HC-MF 73BG2	750	2.4	BK 5-29B-08MEKA	1/29	1.035	13.0

Model	Output [W]	Variable Dimensions																
		LA	LB	LC	LD	LE	LF	LG	LH	LK	L	LR	KL	LZ	Q	S	P	R
HC-MF 73BG2	750	115	95	135	100	8	75	10	85	35	247.5	85	156.7	9	40	25	M6	12
HC-MF 73BG2	750	135	110	155	115	8	90	12	100	40	283.5	100	192.7	11	50	32	M8	16
HC-MF 73BG2	750	150	125	175	130	10	105	15	115	43	283.5	115	192.7	14	60	40	M10	20
HC-MF 73BG2	750	150	125	175	130	10	105	15	115	43	283.5	115	192.7	14	60	40	M10	20

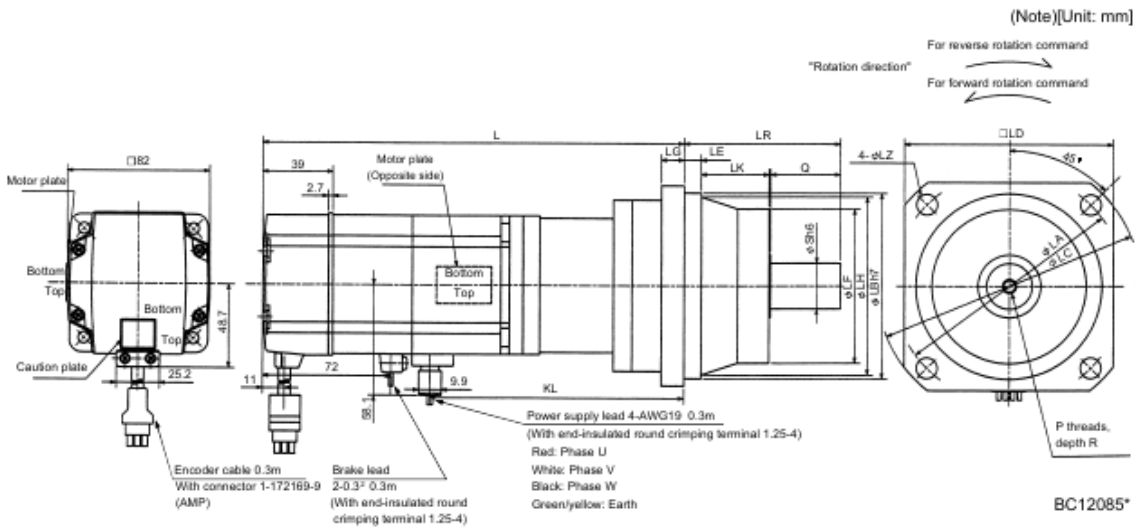

Note: The dimensions without tolerances are reference dimensions.



## 7. OUTLINE DIMENSION DRAWING

### (5) HC-MF-UE · HC-KF-UE series

#### (a) Standard (without electromagnetic brake, without reduction gear)

Model	Output [W]	Variable Dimensions		Inertia Moment $J[\times 10^{-4} \text{kg} \cdot \text{m}^2]$	Weight [kg]
		L	KL		
HC-MF053-UE	50	89.5	37.5	0.019	0.5
HC-MF13-UE	100	104.5	52.5	0.03	0.6
HC-KF053-UE	50	89.5	37.5	0.054	0.5
HC-KF13-UE	100	104.5	52.5	0.085	0.53

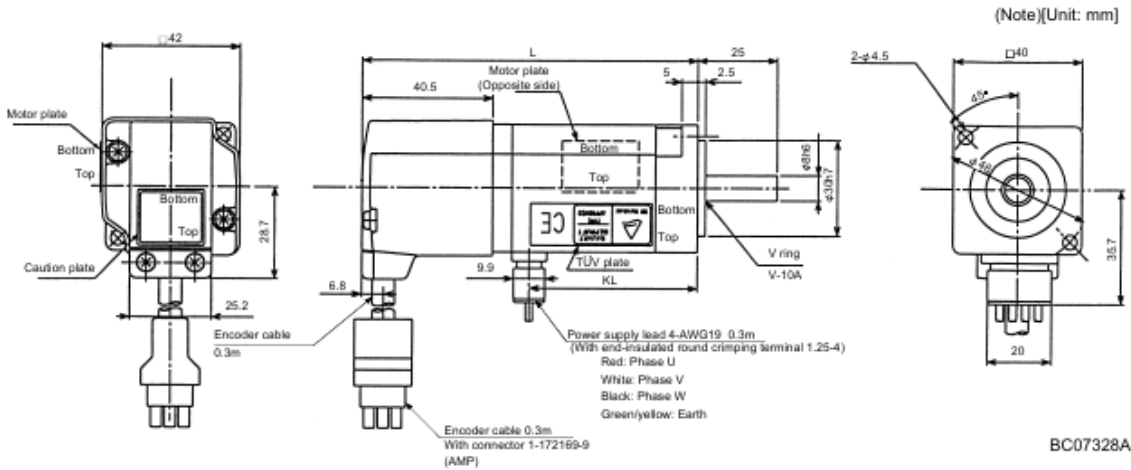

Note: The dimensions without tolerances are reference dimensions.

Model	Output [W]	Variable Dimensions		Inertia Moment $J[\times 10^{-4} \text{kg} \cdot \text{m}^2]$	Weight [kg]
		L	KL		
HC-MF23-UE	200	108.5	58	0.09	1.2
HC-MF43-UE	400	133.5	81	0.14	1.7
HC-KF23-UE	200	108.5	58	0.43	1.2
HC-KF43-UE	400	133.5	81	0.68	1.7

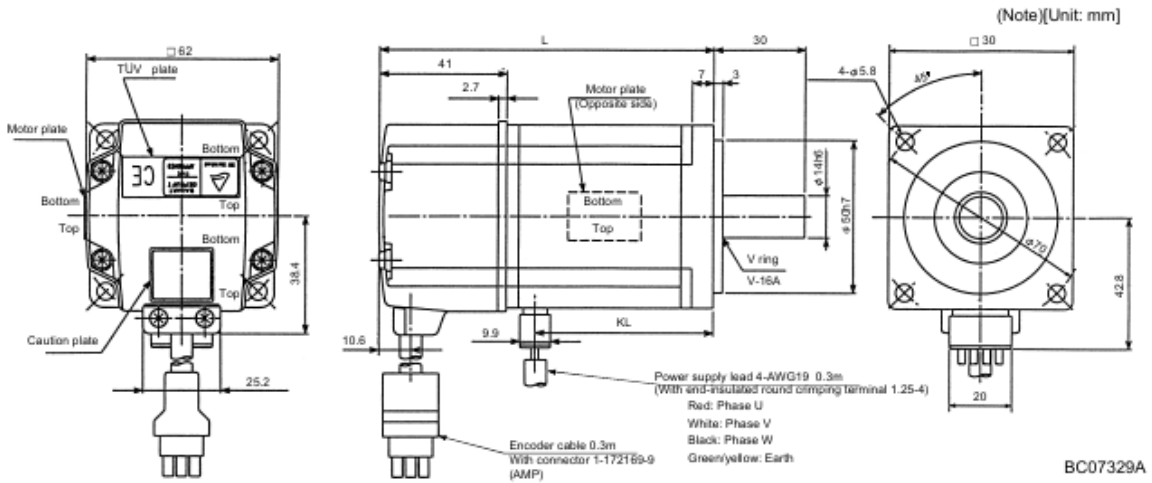

Note: The dimensions without tolerances are reference dimensions.

## 7. OUTLINE DIMENSION DRAWING

Model	Output [W]	Inertia Moment $J[\times 10^{-4} \text{kg} \cdot \text{m}^2]$	Weight [kg]
HC-MF73-UE	750	0.675	3.1

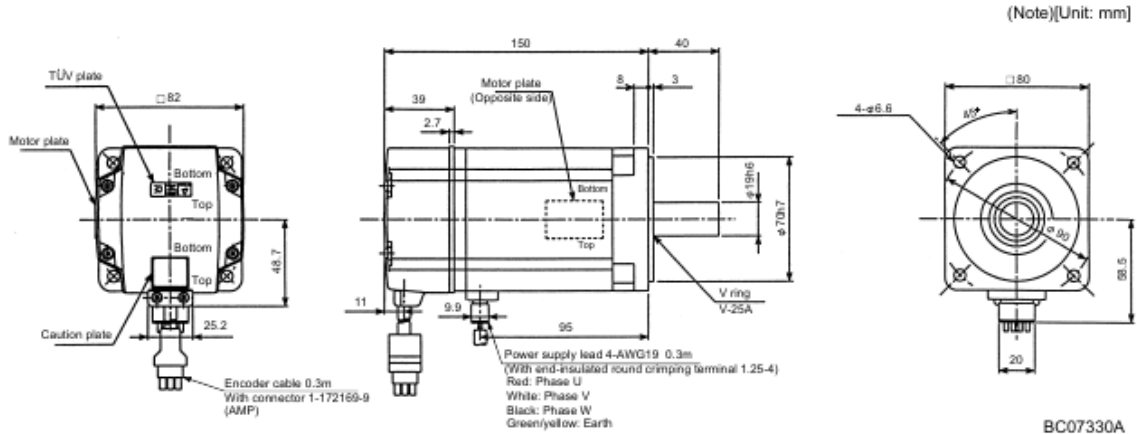

Note: The dimensions without tolerances are reference dimensions.

### (b) With electromagnetic brake

Model	Output [W]	Variable Dimensions		Braking Force [N · m]	Inertia Moment $J[\times 10^{-4} \text{kg} \cdot \text{m}^2]$	Weight [kg]
		L	KL			
HC-MF053B-UE	50	117.5	37.5	0.32	0.022	0.9
HC-MF13B-UE	100	132.5	52.5		0.032	1
HC-KF053B-UE	50	117.5	37.5		0.057	0.9
HC-KF13B-UE	100	132.5	52.5		0.088	1

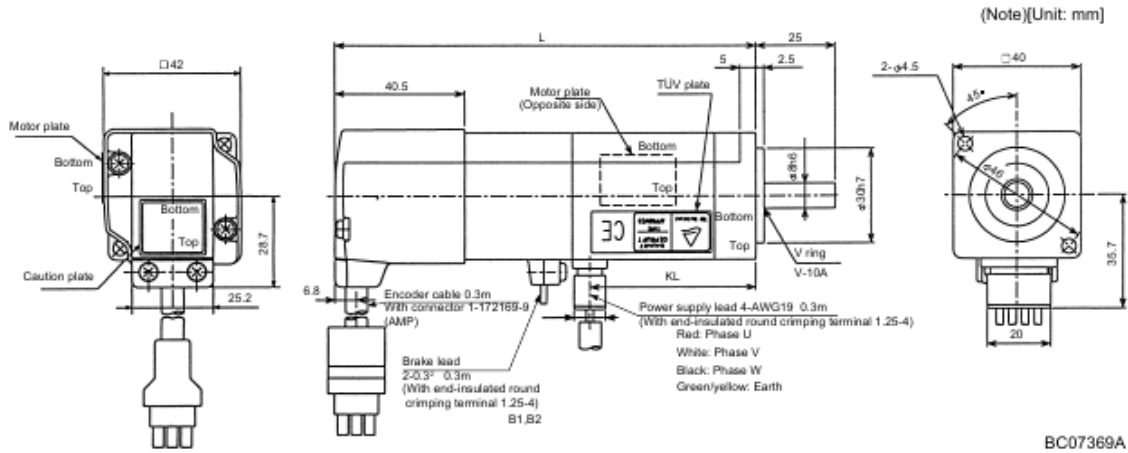

Note: The dimensions without tolerances are reference dimensions.

## 7. OUTLINE DIMENSION DRAWING

Model	Output [W]	Variable Dimensions		Braking Force [N · m]	Inertia Moment J [ $\times 10^{-4}$ kg · m <sup>2</sup> ]	Weight [kg]
		L	KL			
HC-MF23B-UE	200	140.5	58	1.3	0.136	1.7
HC-MF43B-UE	400	165.5	81		0.191	2.2
HC-KF23B-UE	200	140.5	58		0.48	1.7
HC-KF43B-UE	400	165.5	81		0.73	2.2

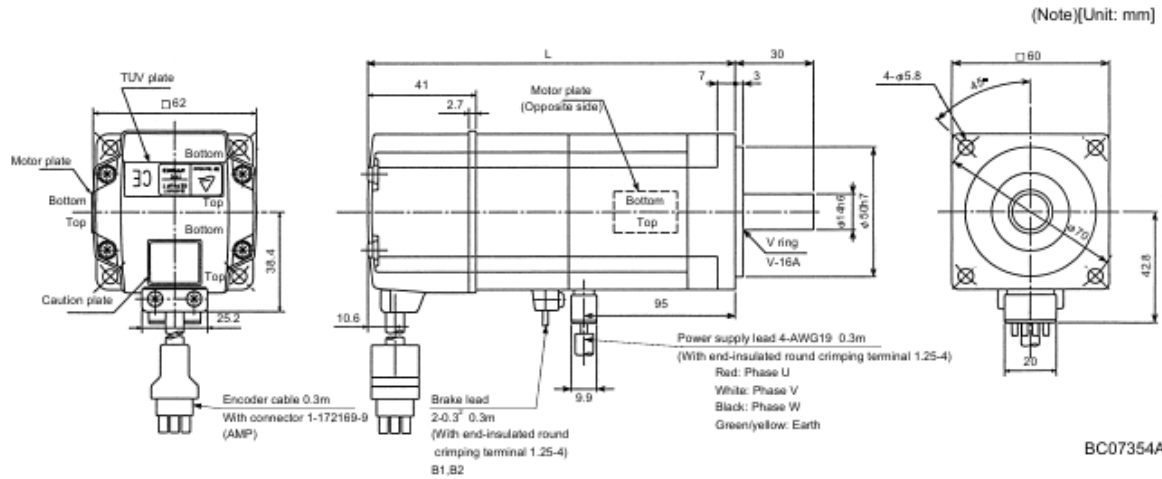

BC07354A

Note: The dimensions without tolerances are reference dimensions.

Model	Output [W]	Braking Force [N · m]	Inertia Moment J [ $\times 10^{-4}$ kg · m <sup>2</sup> ]	Weight [kg]
HC-MF73B-UE	750	2.4	0.75	4.2

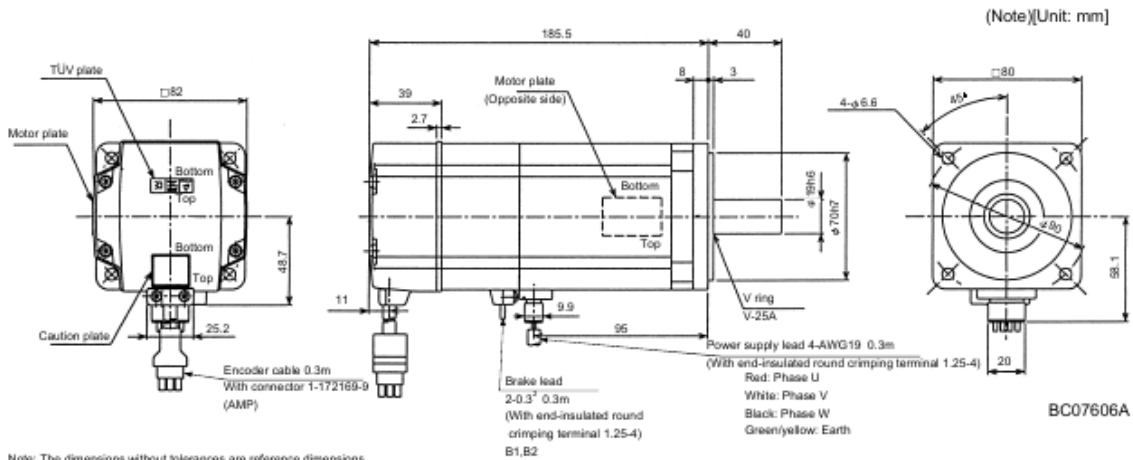

BC07606A

Note: The dimensions without tolerances are reference dimensions.